



锐图

# 激光加工头——焊接系列

## Smart xBeam Delivery——BeamWeld

 上海嘉强自动化技术有限公司  
Shanghai Empower Technologies Co., Ltd.

### 上海总部

地址：上海市松江区东宝路8号  
咨询热线：400-670-1510  
邮箱：sales@empower.cn  
网址：www.empower.cn

### 深圳

深圳嘉强激光技术有限公司  
地址：广东省深圳市宝安区新桥街道新玉路84号B栋105  
电话：0755-26903927

### 苏州

苏州嘉强自动化技术有限公司  
地址：江苏省苏州市常熟市尚湖镇翁庄路16号  
电话：13917215193

### 武汉

武汉嘉强智能技术有限公司  
地址：湖北省武汉市洪山区光谷创业街73号E3116  
电话：027-81302226

### 济南

地址：山东省济南市高新区春晖路2966号智造谷产业园18号楼3楼  
电话：15800670766



@202307



A 数控系统



B 激光传导

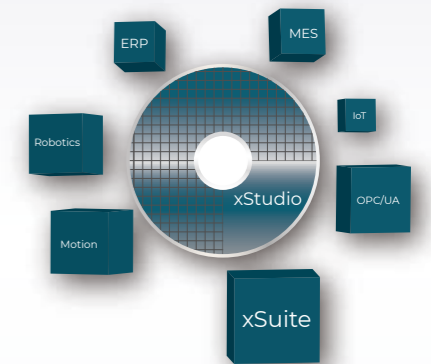

C 工业物联

上海嘉强自动化技术有限公司

# 赋能激光智造 · 综合解决方案



上海嘉强智能工厂基地

Empower嘉强成立于2009年,是激光制造行业的高新技术企业。专注于“xEOS赋能激光智造ABC”——提供基于Ahead-Techs开放数控、BeamTools智能激光头、CloudAhead云端服务的RayTools锐图品牌ABC方案平台。

我们的锐图ABC方案以“锐意进取创新图强”为宗旨,“让激光有智慧,让智造有灵魂,让应用有个性”为愿景,提供专业的一站式智能激光应用开放型xAPP解决方案,包括激光切割、打孔、焊接、熔覆、淬火、表面处理、微加工等制造业基础工具套件。嘉强的公司使命是致力于打造激光中央厨房和OEM渠道嘉强合作开放分布式总线创新型方案,促进激光装备生产力,将激光应用融合进下游的千行百业,为智能激光制造服务并与集成商和渠道共赢共创价值。

Founded in 2009, Shanghai Empower Technologies Co.,Ltd. is a high-tech enterprise in the laser manufacturing industry. Since its inception, Empower strives for "xEOS Empower Laser Smart ABC", providing RayTools ABC solutions based on AheadTechs CNC, BeamTools smart laser head, and CloudAhead cloud services.

We set the aim of RayTools ABC solutions as "advance with innovation and strength" and the vision as "Creating Unique Smart Laser & Automation". Starting with the two concepts, we provide professionally one-stop xAPP solutions for intelligent laser applications, covering laser cutting, drilling, welding, cladding, hardening, surface treatment, micro-processing, and other basic tools for manufacturing.

We attempt to build an open laser system and overall innovative solutions featuring OEM Empower open cooperation & distribution mode. By doing so, we act to promote the productivity of laser equipment and the integration of laser applications into the downstream industries, further creating value for intelligent laser manufacturing and win-win cooperation with integrators and developing channels.

## 使命 Mission

打造激光中央厨房,创新综合解决方案  
促进智能装备生产力,为激光服务共创价值  
Empower Openlaser Systems

## 愿景 Vision

让激光有智慧 让智造有灵魂 让应用有个性  
Open-Minded Machinery and Automations

## 价值观 Value

嘉言善行 庄敬自强  
Doing Good Deeds

# 赋能激光智造

Empower Openlaser Systems

xMotion

数控系统



xLaser

激光传导



xConnect

工业物联



# 我们的产品可以做什么

三维切割3D Cutting



平面切割Flat Cutting

熔覆Cladding

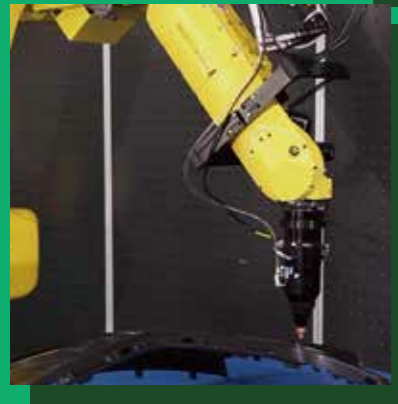

三维非金属切割3D Non-metal Cutting

精密切割Micro Cutting



焊接Welding



WHAT  
WE  
DO



# 全球网络 Global Network



## 产品业务完整 A Board Range of Products and Turnkey Solutions

从激光加工头、配件、定制模块，到整体激光综合加工方案，我们提供5000多种产品，可满足各种工业激光应用需求。

We offer more than 5000 SKU off the shelf, including laser processing heads, accessories, customized modules and turnkey solutions to meet needs of various industrial laser applications.

## 客户规模大 Large Scale Customer Base

拥有近2000多家客户，其中国内覆盖全国30个省市，国际拥有美洲、欧洲、亚洲等100多家客户。

With more than 2000 clients, among which there are more than 100 overseas clients, our customer base covers 30 domestic provinces and international markets like America, Europe, and Asia.

## 开放技术平台 Open Platform and Sustainable Innovation

借助我们的开放式x CNC软件和xBeamDelivery模块平台，我们可以为您的特定应用场景定制激光头产品、嵌入式软件或解决方案套件。

我们获得了超过100项专利和版权，并且还有更多项目正在进行中，我们的团队从未停止创新。

With our open platform of xCNC software and xBeamDelivery modules, laser processing heads, the embedded software and solution kits can be customized to clients' needs based on specific applications. With over 100 patents and copyrights and more projects in progress, our innovation never stops.

## 服务响应快 Fast Response Service

拥有深圳、苏州、武汉、济南办事处，我们秉持“12小时响应、48小时上门”的服务宗旨，全心全意为客户提供优质的一站式服务。

With offices in the cities of Shenzhen, Suzhou, Wuhan and Jinan, we adhere to the purpose of "12-hour response, 48-hours door-to-door" service and wholeheartedly provide our customers with quality one-stop service.

服务热线：  
Hotline **400-670-1510**

服务邮箱：  
Service Email **service@empower.cn**

## ShangHai

### 上海总部

地址：上海市松江区东宝路8号

邮箱：sales@empower.cn

网址：www.empower.cn

热线：400-670-1510

转1号键售前产品订购咨询

转2号键售后上门维修咨询

转3号键产品返厂维修咨询

传真：(021) 6760-1511

## ShenZhen 深圳

座机：(0755) 2690-3927

地址：广东省深圳市宝安区新桥街道新玉路84号

B栋105、205

## Suzhou 苏州

地址：江苏省苏州市常熟市尚湖镇翁庄路16号

## WuHan 武汉

座机：(027) 8130-2226

地址：湖北省武汉市东湖洪山区光谷创业街73号

E3116

## JiNan 济南

地址：山东省济南市高新区春晖路2966号

智造谷产业园18号楼301-306

## USA 美国

座机：1-781-995-7305

地址：10 Wedge Pond Road, Winchester, MA 01890

USA

## Switzerland 瑞士

座机：+41-788274963

地址：Emmentalstrasse 96, CH-3414 Oberburg,

Switzerland

# 目录

## CONTENT

### / 手持系列

Handle Series

- 01 **BW101-GS** 单振镜手持焊接头 2kW/3kW  
Single Galvo Handheld Welding Head
- 03 **BW101-GD** 双振镜手持焊接头 2kW  
Dual Galvo Handheld Welding Head
- 05 **BN101-GS** 手持清洗头 2kW  
Handheld Cleaning Head

### / BW焊接系列

BW Series

- 07 **BW210** 透射式激光焊接头 3kW  
Laser Welding Head - Transmission Type
- 09 **BW240** 透射式激光焊接头 6kW  
Laser Welding Head - Transmission Type
- 11 **BW06L** 宽波段焊接头 6kW  
Broad-wavelength Welding Head
- 13 **BW290-8W** 宽波段焊接头 8kW  
Broad-wavelength Welding Head
- 15 **BW290-6D** 双波段复合焊接头 6kW  
Dual-wavelength Hybrid Welding Head
- 17 **BW290-6B** 双波段复合摆动焊接头 6kW  
Dual-wavelength Hybrid Wobble Welding Head
- 19 **BW290-ZOOM** 自动变焦智能焊接/熔覆/淬火头 6kW  
Smart Auto Zoom Welding/Cladding/Hardening Head
- 21 **BW310** 双焦点旋转焊接头 4kW  
Dual-spot Welding Head
- 23 **BW12K/BW20K** 透射式激光焊接头 12kW/20kW  
Laser Welding Head - Transmission Type

### / BF/BG焊接系列

BF/BG Series

- 25 **BF320** 同轴搅拌焊接头 3kW  
Coaxial Wobble Welding Head
- 27 **BF02K-MINI** 摆动焊接头 2kW  
Wobble Welding Head
- 29 **BF03S** 摆动焊接头 2kW/3kW  
Wobble Welding Head
- 31 **BF330-2F** 摆动焊接头 2kW  
Wobble Welding Head
- 33 **BF330-4F** 摆动焊接头 4kW  
Wobble Welding Head
- 35 **BF330-6F** 摆动焊接头 6kW  
Wobble Welding Head
- 37 **BF12K** 摆动焊接头 12kW  
Wobble Welding Head
- 39 **BG03S** 振镜焊接头 3kW  
Galvo Laser Welding Head
- 41 **BG04K** 振镜焊接头 4kW  
Galvo Laser Welding Head
- 43 **BF330-6C** 振镜焊接头 6kW  
Galvo Laser Welding Head

### / AK焊接系列

AK Series

- 45 **AK390-BW** 高功率多功能激光加工头——焊接 20kW  
High Power Multifunctional Laser Welding Head

### / 熔覆系列

Cladding Series

- 47 **AK190-TC** 反射式激光加工头——熔覆 6kW  
Laser Cladding Head - Parabolic Type
- 49 **AK390-TC** 高功率多功能激光加工头——熔覆 20kW  
High Power Multifunctional Laser Cladding Head
- 51 **AK390-PC** 高功率多功能激光加工头——宽带熔覆 20kW  
High Power Multifunctional Wideband Laser Cladding Head
- 53 **BC104** 透射式激光熔覆头 4kW  
Laser Cladding Head - Transmission Type
- 55 **BC106** 透射式高功率激光熔覆头 6kW  
High Power Laser Cladding Head - Transmission Type
- 57 **VB106** 多功能激光加工头 6kW  
Multifunctional Laser Processing Head
- 59 **IC104** 内孔激光熔覆头 4kW  
Inner Tube Laser Cladding Head

### / 淬火系列

Hardening Series

- 61 **AK090-HT** 激光淬火头 3kW  
Laser Hardening Head
- 63 **AK190-HT** 多功能激光加工头——淬火 3kW  
Multifunctional Laser Hardening Head
- 65 **AK390-HT** 高功率多功能激光加工头——淬火 6kW-20kW  
High Power Multifunctional Laser Hardening Head

### / 封边系列

Banding Series

- 67 **BF340-3F** 单振镜激光封边头 3kW  
Single Galvo Laser Banding Head
- 69 **BW420** 连续可调矩形光斑封边头 4kW  
Continuously Adjustable Rectangular Spot Banding Head
- 71 **AK090-4FA** 固定矩形光斑封边头 4kW  
Fixed Rectangular Spot Banding Head
- 73 **AK090-4FB** 可调矩形光斑封边头 4kW  
Adjustable Rectangular Spot Banding Head
- 75 **AK090-4FC** 连续可调矩形光斑封边头 4kW  
Continuously Adjustable Rectangular Banding Head

### / 解决方案

Laser Solutions Kits

- 77 **焊接控制系统**  
Welding Control System
- 79 **新能源焊接平台**  
New Energy Welding Station
- 81 **熔覆解决方案**  
Cladding Solution
- 83 **精细管材激光加工解决方案**  
Laser Processing Solution for Precision Tube

### / 配件辅件

Accessories

- 85 **送粉器**  
Powder Feeder
- 86 **焊接寻位系统**  
Weld Seam Tracking
- 87 **测温模块**  
Laser Pyrometer
- 88 **红光指示器**  
Aiming Laser
- 88 **CCD成像辅助**  
CCD Imaging Assistant
- 89 **准直组件**  
Collimation Module

# BW101-GS

## 单振镜手持焊接头

Single Galvo Handheld Welding Head

功率等级  
Power Rating

2kW/3kW

更多信息请扫描二维码  
Scan to get details



## 单振镜手持焊接头

Single Galvo Handheld Welding Head

重量轻体积小, 操作简单, 符合人体工程学设计

Light-duty with compact size, easy to operate, and ergonomically designed.

## 安全防护

High Security

多重安全防护, 离开工件无法出光, 安全性高

With multiple safety protections, no laser beam will be out without the workpiece to ensure high security.

## 优化设计

Optimized Design

双保护窗设计, 防尘防渣设计, 产品稳定可靠

Dual cover glass design to proof dust and slag makes the product to be stable and reliable.



\*产品图片仅供参考  
\* For Reference Only

## 工艺优点

Technological Advantages

连续焊接, 鱼鳞点焊,  
适应各种焊接方式

Suitable for various welding techniques, like continuous welding and spot welding.

## 可选配双送丝功能

Optional Dual-wire Feeding Function

选配双送丝机、双送丝组件,  
实现厚板宽焊缝焊接

Dual-wire feeder and dual-wire feeding assembly for wide welding seam of thick sheet.

## 多合一功能

Multiple Functions

配有多种用途喷嘴选型, 满足焊接、切割、  
焊缝清洗、远程清洗等多种功能

Various tip assemblies in standard kit to fulfill needs of cutting, welding, welding seam cleaning and remote cleaning.

## 技术参数 Technical Data

功率等级 Power Rating	2000W/3000W
通光孔径 Clear Aperture	10mm
摆动幅度 Wobble Size	0-5mm
适用波长 Applicable Wavelength	1070nm
重量 Weight	~0.9kg

## 系统配件 Accessories

控制盒  
Control Box



## 选配 Optional

送丝机  
Wire Feeding Machine

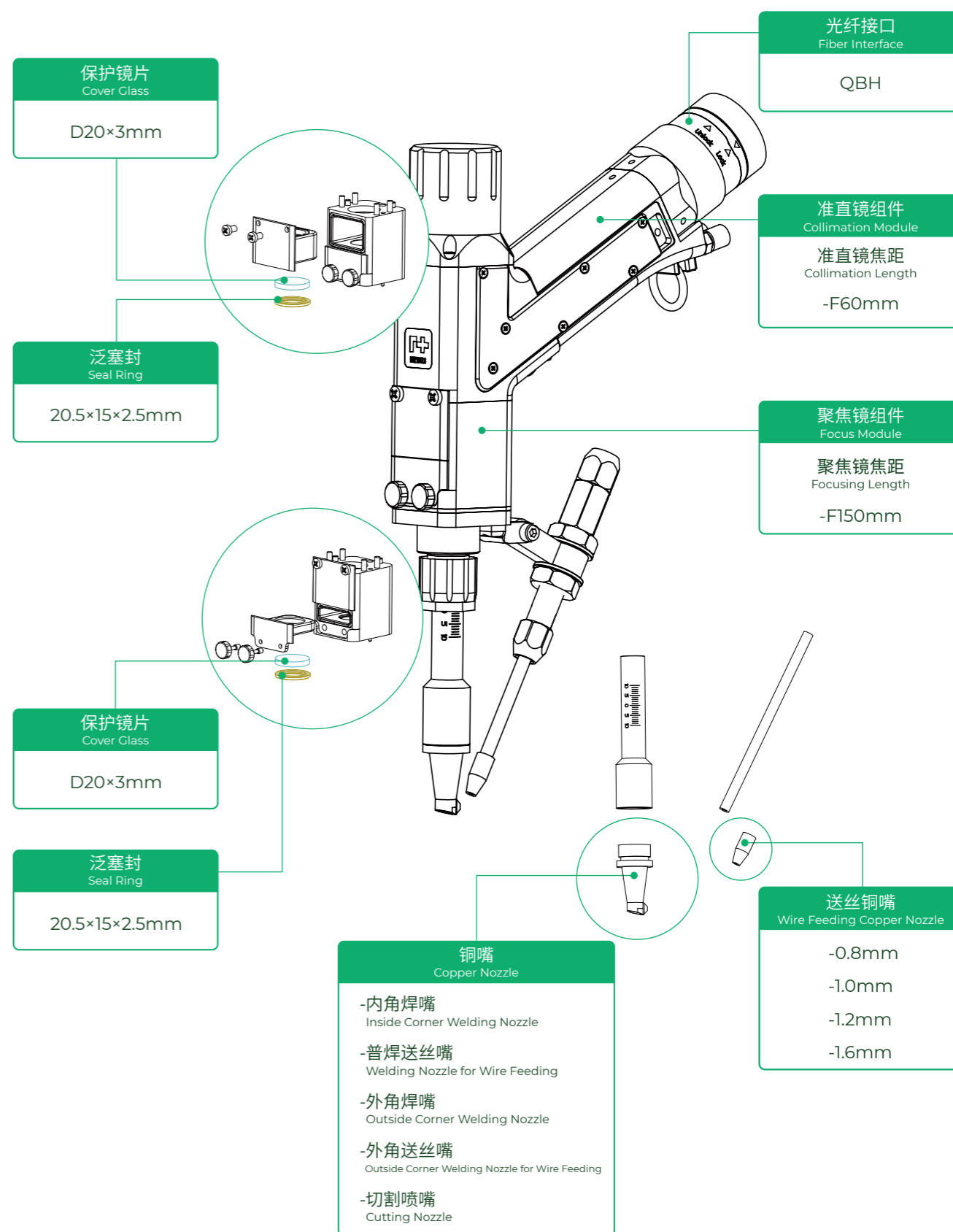

# BW101-GD

## 双振镜手持焊接头

Dual Galvo Handheld Welding Head

功率等级  
Power Rating **2kW**



更多信息请扫描二维码  
Scan to get details

## 双振镜手持焊接头

Dual Galvo Handheld Welding Head

重量轻体积小, 操作简单, 符合人体工程学设计

Light-duty with compact size, easy to operate, and ergonomically designed.

## 安全防护

High Security

多重安全防护, 离开工件无法出光, 安全性高

With multiple safety protections, no laser beam will be out without the workpiece to ensure high security.



\*产品图片仅供参考  
\* For Reference Only

## 优化设计

Optimized Design

双保护窗设计, 防尘防渣设计, 产品稳定可靠  
Dual cover glass design to proof dust and slag makes the product to be stable and reliable.

## 工艺优点

Technological Advantages

8种摆动图形, 满足客户不同工艺需求  
With 8 different kinds of graphics for wobble welding, meets customers' various process requirements.

## 可选配双送丝功能

Optional Dual-wire Feeding Function

选配双送丝机、双送丝组件,  
实现厚板宽焊缝焊接

Dual-wire feeder and dual-wire feeding assembly for wide welding seam of thick sheet.

## 技术参数 Technical Data

功率等级 Power Rating	2000W
通光孔径 Clear Aperture	8mm
X轴摆动幅度 X-Axis Wobble Size	0-5mm
Y轴摆动幅度 Y-Axis Wobble Size	0-5mm
适用波长 Applicable Wavelength	1070nm
重量 Weight	~1.0kg

## 系统配件 Accessories

控制盒  
Control Box



## 选配 Optional

送丝机  
Wire Feeding Machine

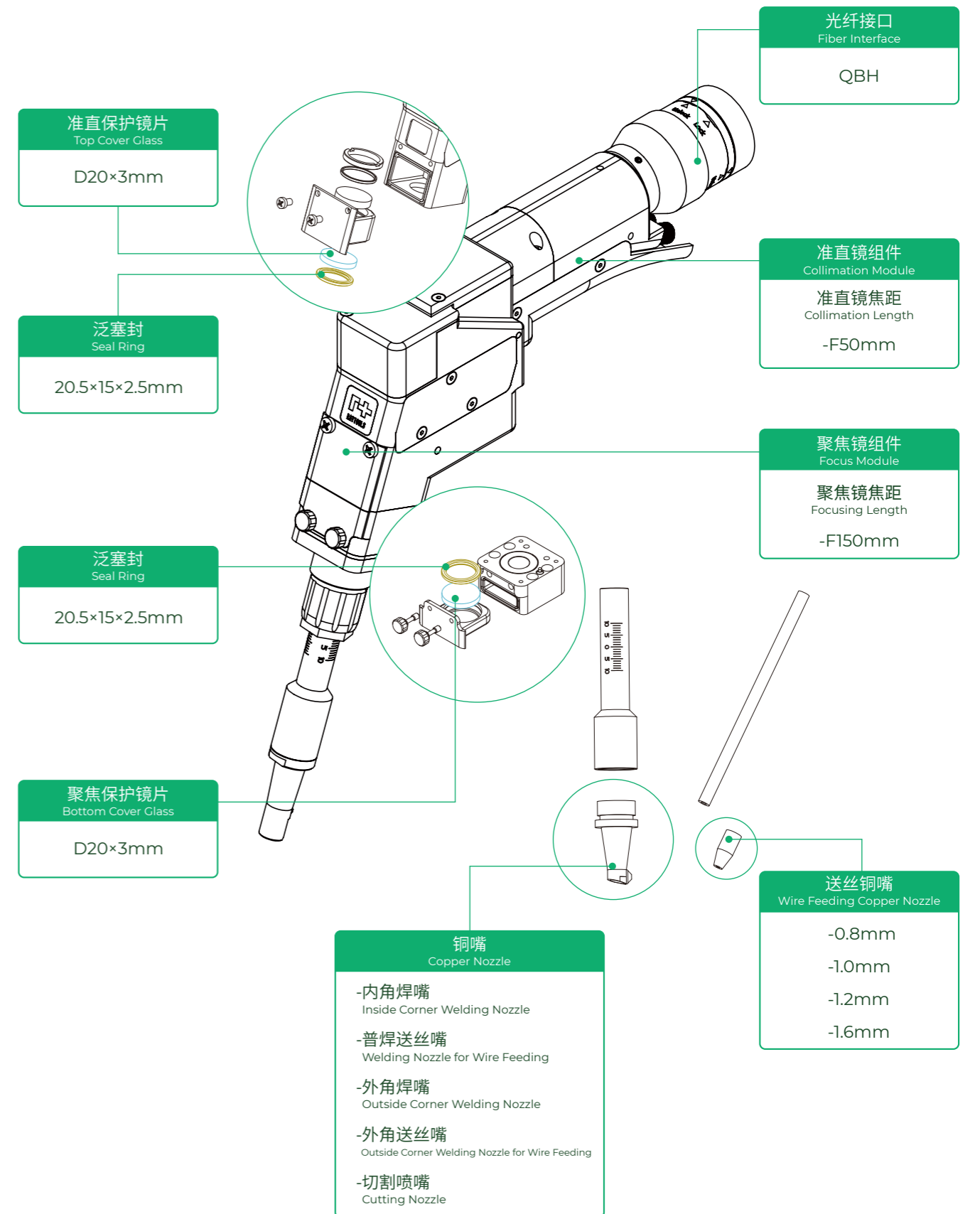



# BN101-GS

手持清洗头

Handheld Cleaning Head

功率等级 **2kW**  
Power Rating



更多信息请扫描二维码  
Scan to get details

## 单振镜手持清洗头

Hollow Motor Handheld Welding Head

重量轻体积小, 操作简单, 符合人体工程学设计  
Light-duty with compact size, easy to operate, and ergonomically designed.

## 操作简单易上手

High Security

操作简单, 可编辑工艺库, 直接调用开始高效清洗。  
Convenient and easy to operate. Convenient to operate, with an editable process library that can be used directly to start efficient cleaning.

## 工艺设置

Process Settings

工艺参数可调节性强, 可针对不同场景精准把控工艺参数, 高效清洗不伤基材。

The process parameters are highly adjustable and can be precisely controlled for different scenarios, allowing efficient cleaning without damaging the substrate.



\*产品图片仅供参考  
\* For Reference Only

## 优化设计

Optimized Design

气帘保护设计, 防尘防渣, 旋转光闸设计, 产品安全稳定可靠。  
Air curtain protection design, dust-proof and slag-proof, rotating shutter design and product featuring safety, stability and reliability.

## 安全防护

High Security

多重安全防护, 安全性高, 有效保障生产安全。  
Multiple safety guards for high security and effective production safety.

## 技术参数 Technical Data

功率等级 Power Rating	2000W
通光孔径 Clear Aperture	10mm
摆动幅度 Wobble Size	0-300mm
适用波长 Applicable Wavelength	1070±10nm
重量 Weight	~0.85kg

## 系统配件 Accessories

控制盒  
Control Box

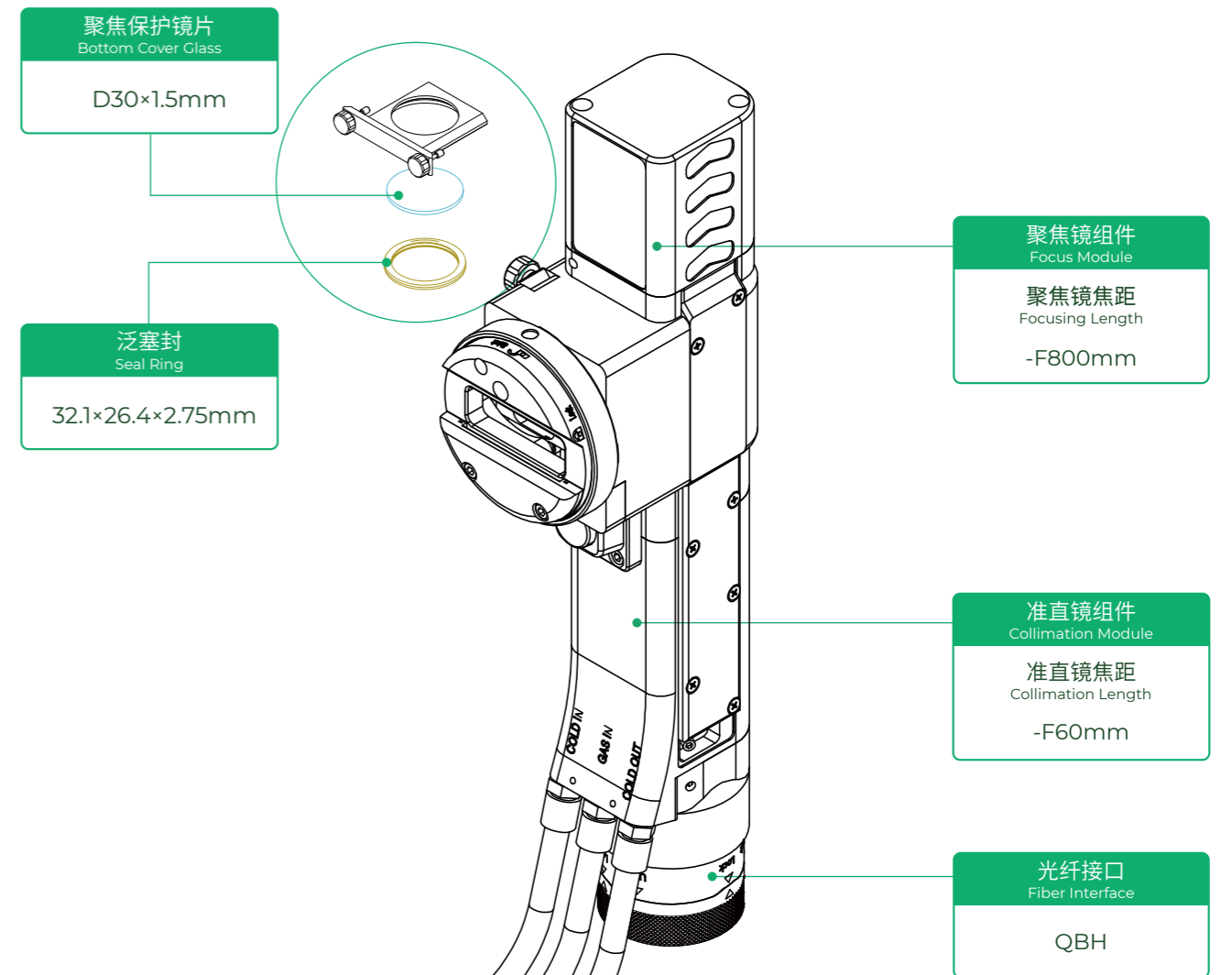



# BW210

透射式激光焊接头

Laser Welding Head - Transmission Type

功率等级

Power Rating

3kW



更多信息请扫描二维码  
Scan to get details

## 高性价比

Highly Cost-effective

可适配低功率半导体及光纤激光焊接市场需求, 适用于黑色金属及有色金属

Applicable to low power diode and fiber laser welding market demand, and work with all kinds of metal.

## 高效冷却

Efficient Cooling

准直镜和聚焦镜座均设置水冷, 能够长时间稳定工作, 延长使用寿命

Both collimation and focus lens are water cooled for long work duration and stability, to prolong lifespan.



\*产品图片仅供参考  
\* For Reference Only

## 焊接效果优异

Excellent Welding Effect

优化的光学设计, 实现高速、高质量的低功率激光焊接

Optimized optical design enables high-speed and high quality low power laser welding.

## 扩展模块丰富

Rich Function Expanding

可扩展焊缝跟踪或寻位功能等模块, 易于实现自动化焊接

Modules like seam tracking and positioning are optional for expanding of function. Make it easy to realize auto welding.

## 优质的气流设计

High Quality Gas Circuit

采用平滑高效的流体结构设计, 能获得优质的熔池保护效果

Efficient fluid structure design for the excellent effect of protection to the melting pool.

## 技术参数 Technical Data

功率等级 Power Rating	3000W
激光波长 Laser Wavelength	光纤1064nm, 半导体 915nm, 蓝光450nm Fiber 1064nm, Diode 915nm, Blue Laser 450nm

通光孔径 Clear Aperture	28mm
重量 Weight	~3.0kg

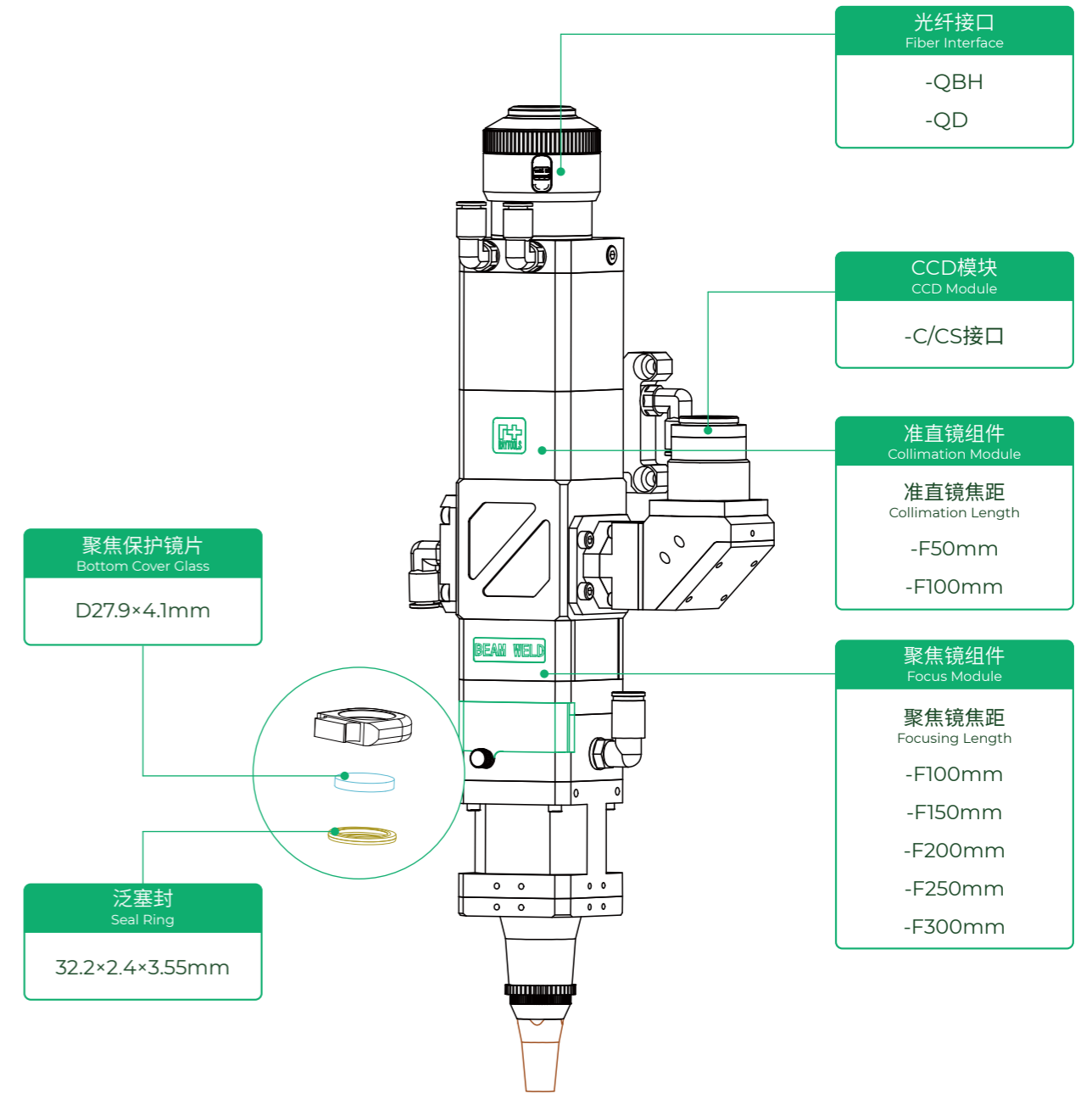

**可选末端组件**  
Optional Tip Assembly

**气刀保护组件**  
Air Knife Protection Assembly

**可选末端组件**  
Optional Tip Assembly

**同轴保护组件**  
Coaxial Protection Assembly

- F100mm
- F150mm
- F200mm
- F250mm
- F300mm

# BW240

## 透射式激光焊接头

Laser Welding Head - Transmission Type

功率等级 **6kW**  
Power Rating



更多信息请扫描二维码  
Scan to get details

### 高性价比

Highly Cost-effective

兼容市场上主流光纤激光器的波长范围，  
6kW功率范围的高性价比产品

Compatible to the wavelength range of prevailing fiber lasers in market, work with cost-effective products of 6kW power rating.

### 高效冷却

Efficient Cooling

准直镜和聚焦镜座均有优异的水冷，能够  
长时间稳定工作，延长使用寿命

Both collimation and focus lens are water cooled for long work duration and stability, to prolong lifespan.

### 焊接效果优异

Excellent Welding Effect

采用优化的光学设计，完成深熔焊接，焊缝深宽比大，  
中厚板焊接更有利

With the optimized optical design, easy to realize the deep penetration welding. With large depth-to-width ratio of the welding, more favorable to weld medium/thick plate.



\*产品图片仅供参考  
\* For Reference Only

### 高度防尘

Excellent Dustproof

双保护镜片设计，有效防止落灰引起  
镜片的损毁，增加焊接头使用寿命  
Dual cover glass to protect collimation and focus lens from damage caused by dust and prolong the lifespan of the welding head.

### 扩展模块丰富

Rich Function Expanding

可扩展焊缝跟踪或寻位功能等  
模块，易于实现自动化焊接  
Modules like seam tracking and positioning are optional for expanding of function. Make it easy to realize auto welding.

### 优质的气流设计

High Quality Gas Circuit

同轴、旁轴保护喷嘴和气刀采用平滑  
高效的流体结构设计，能获得优异的  
熔池保护效果与焊渣吹除效果  
Efficient fluid structure design of the coaxial nozzle, side-blow nozzle and air knife assembly for the excellent effect of slag blowing and protection to the melting pool.

## 技术参数 Technical Data

功率等级 Power Rating	6000W
激光波长 Laser Wavelength	1064nm

通光孔径 Clear Aperture	35mm
重量 Weight	~4.0kg

准直保护镜片  
Top Cover Glass  
D37×1.6mm

聚焦保护镜片  
Bottom Cover Glass  
D37×7mm

泛塞封  
Seal Ring  
42.5×4×3.2mm

光纤接口  
Fiber Interface  
-QBH  
-QD  
-LLK-D

CCD模块  
CCD Module  
-C/CS接口

准直镜组件  
Collimation Module  
准直镜焦距  
Collimation Length  
-F100mm  
-F150mm

聚焦镜组件  
Focus Module  
聚焦镜焦距  
Focusing Length  
-F200mm  
-F250mm  
-F300mm  
-F400mm  
-F500mm

喷嘴  
Nozzle  
同轴保护喷嘴  
Coaxial Nozzle

可选末端组件  
Optional Tip Assembly

短焦气刀保护组件  
Air Knife Protection Assembly-Short Focal

长焦气刀保护组件  
Air Knife Protection Assembly-Long Focal

可选末端组件  
Optional Tip Assembly

同轴保护组件  
Coaxial Protection Assembly

- F200mm
- F250mm
- F300mm
- F400mm

# BW06L

## 宽波段焊接头

Broad-wavelength Welding Head

功率等级 **6kW**  
Power Rating



更多信息请扫描二维码  
Scan to get details

## 透射式激光焊接头

Transmissive Laser Welding Head

高性价比, 适配高功率半导体及光纤激光焊接  
市场需求, 适用于黑色金属及有色金属

Cost-effective, matching the need of high-power semiconductor and fiber laser welding markets for ferrous and non-ferrous metals.

## 智能监控

Smart Monitoring

准直聚焦镜工作温度实时监控, 保护镜  
到位信号报警

Real-time monitoring of the operating temperature of the collimation focusing mirror with signal alarm for the protection mirror in place.

## 焊接效果优异

Excellent Welding Effect

优化的光学设计, 实现高速、高质量  
的高功率激光焊接

Optimized optical design enables high-speed and high quality high power laser welding.



\*产品图片仅供参考  
\* For Reference Only

## 高效冷却

Efficient Cooling

准直镜和聚焦镜座均设置水冷, 能够  
长时间稳定工作, 延长使用寿命

Both collimation and focus lens are water cooled for long work duration and stability, to prolong lifespan.

## 优质的气流设计

High Quality Gas Circuit

采用平滑高效的流体结构设计,  
能获得优异的保护熔池效果

Efficient fluid structure design for the excellent effect of protection to the melting pool.

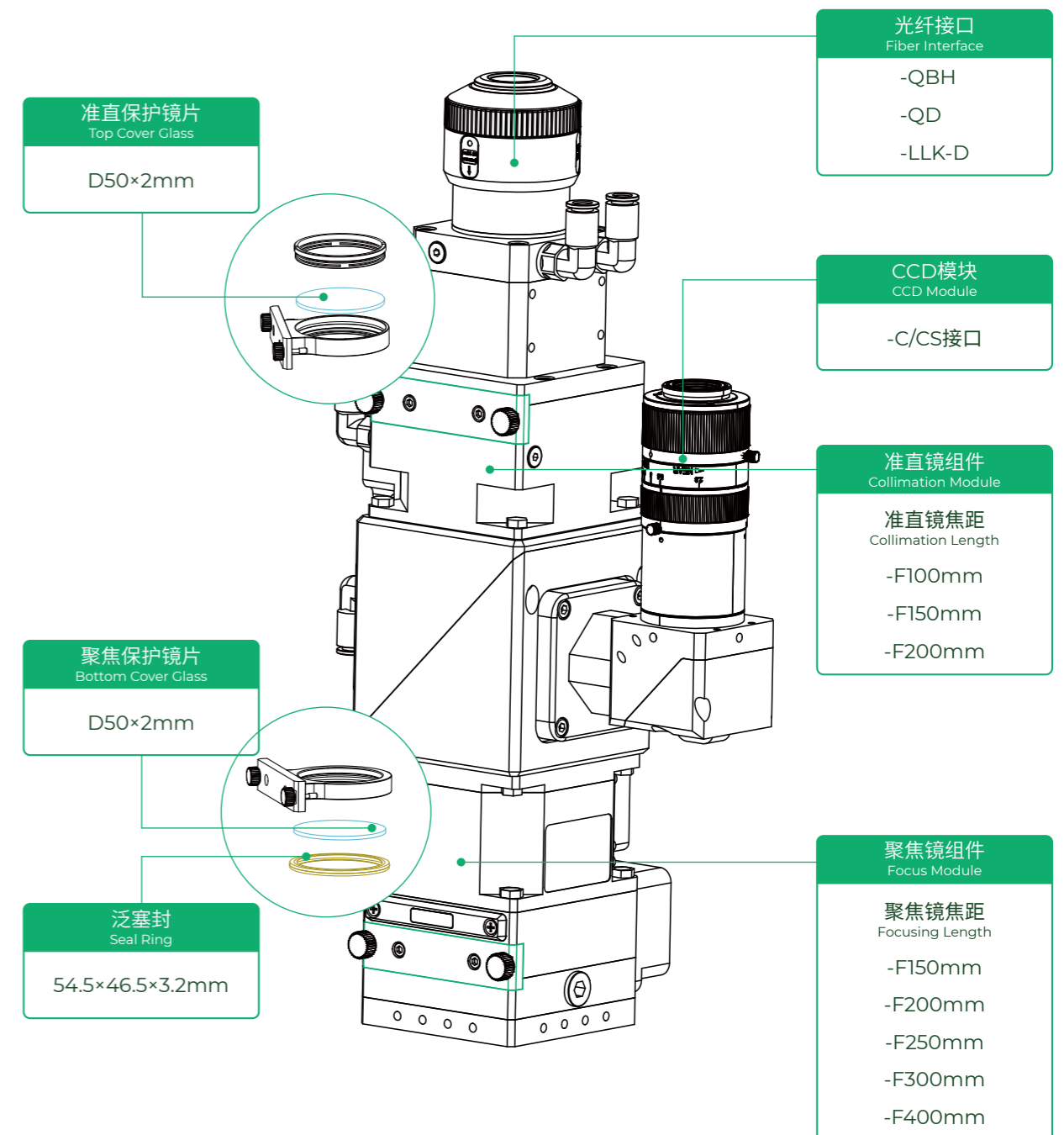

## 技术参数 Technical Data

功率等级 Power Rating	6000W
激光波长 Laser Wavelength	900-1100nm

通光孔径 Clear Aperture	47mm
重量 Weight	~4.5kg

可选末端组件  
Optional Tip Assembly



气刀保护组件  
Air Knife Protection Assembly

可选末端组件  
Optional Tip Assembly

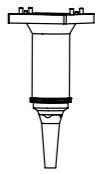

同轴保护组件  
Coaxial Protection Assembly

- F150mm
- F200mm
- F250mm
- F300mm
- F400mm

# BW290-8W

宽波段焊接头

Broad-wavelength Welding Head

功率等级 **8kW**  
Power Rating



更多信息请扫描二维码  
Scan to get details

## 高性价比

Highly Cost-effective

可适配高功率半导体及光纤激光焊接市场需求，适用于黑色金属及有色金属

Applicable to high power welding of ferrous/non-ferrous metal by diode or fiber laser.

## 智能监控

Smart Monitoring

可实时监测准直聚焦镜的工作温度及保护镜的插拔与否

Real-time monitoring of the ambient temperature of collimation lens and focus lens, and checking the work state of cover glass.

## 焊接效果优异

Excellent Welding Effect

优化的光学设计，实现高速、高质量的高功率激光焊接

Optimized optical design enables high-speed and high quality high power laser welding.

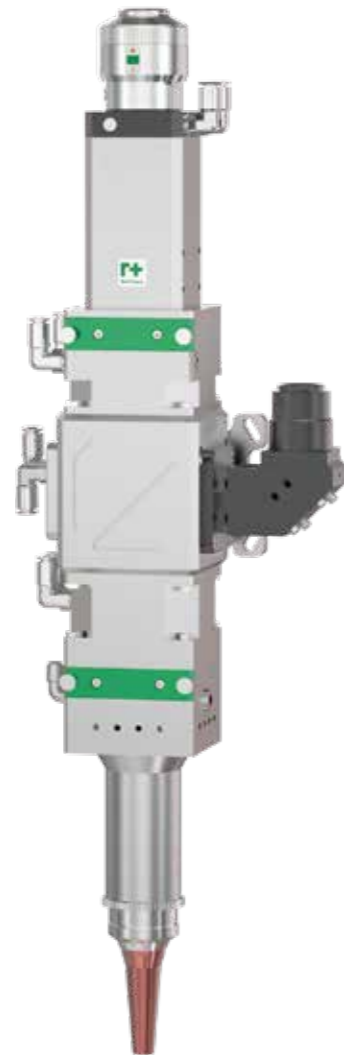

\*产品图片仅供参考  
\* For Reference Only

## 高效冷却

Efficient Cooling

准直镜和聚焦镜座均设置水冷，能够长时间稳定工作，延长使用寿命

Both collimation and focus lens are water cooled for long work duration and stability, to prolong lifespan.

## 扩展模块丰富

Rich Function Expanding

可扩展焊缝跟踪或寻位功能等模块，易于实现自动化焊接

Modules like seam tracking and positioning are optional for expanding of function. Make it easy to realize auto welding.

## 优质的气流设计

High Quality Gas Circuit

采用平滑高效的流体结构设计，能获得优异的熔池保护效果

Efficient fluid structure design for the excellent effect of protection to the melting pool.

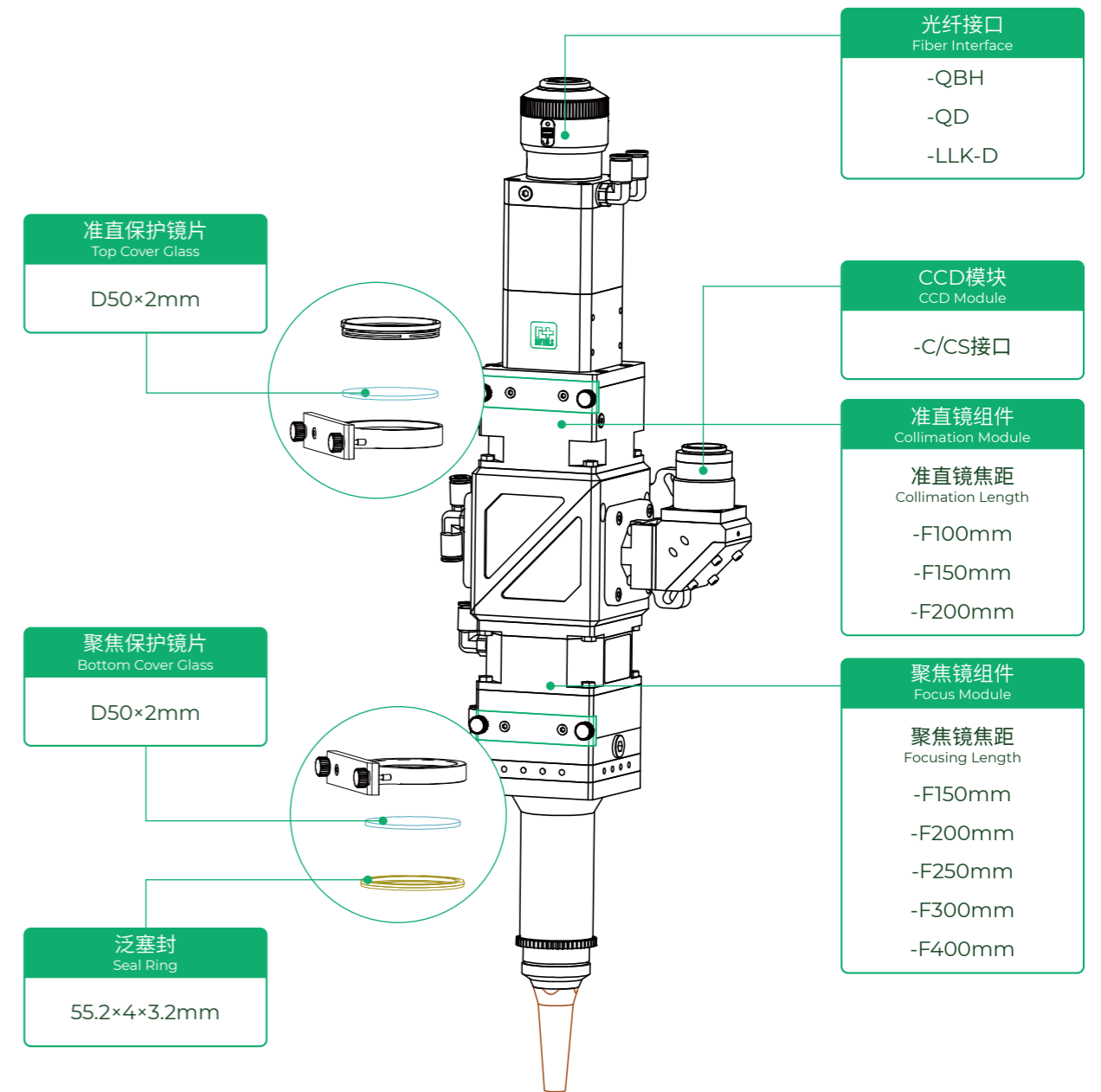

## 技术参数 Technical Data

功率等级 Power Rating	8000W
激光波长 Laser Wavelength	900-1100nm

通光孔径 Clear Aperture	48mm
重量 Weight	~4.5kg

**可选末端组件**  
Optional Tip Assembly



**气刀保护组件**  
Air Knife Protection Assembly

**可选末端组件**  
Optional Tip Assembly

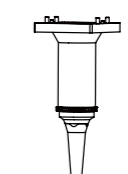

**同轴保护组件**  
Coaxial Protection Assembly

- F150mm
- F200mm
- F250mm
- F300mm
- F400mm



# BW290-6D

双波段复合焊接头  
Hybrid Wavelength Welding Head

功率等级 6kW  
Power Rating



更多信息请扫描二维码  
Scan to get details

## 焊接效果优异

Excellent Welding Effect

主要应用于高反材料焊接, 提高焊缝质量, 确保焊缝的一致性  
Mainly used for welding of high-reflection materials and to secure the quality and consistency of welding seam.



\*产品图片仅供参考  
\* For Reference Only

## 扩展模块丰富

Rich Function Expanding

可扩展焊缝跟踪或寻位功能等模块, 易于实现自动化焊接  
Modules like seam tracking and positioning are optional for expanding of function. Make it easy to realize auto welding.

## 抽屉式镜座

Drawer Type Lens Holder

保护镜片更换快速、简单  
Drawer type cover glass holder to facilitate replacement.

## 高效冷却

Efficient Cooling

双水冷结构设计, 保护镜镜座及激光头本体带有水冷接口, 延长持续工作时长  
Dual water cooling structure with interfaces on both the cover glass holder and the laser head to extend the working duration.

## 高度防尘

Excellent Dustproof

牢靠的密封性设计, 可以有效避免光学镜片污染, 提高使用寿命  
Reliable sealing design to avoid contamination to optical lens and prolong the lifespan.

## 技术参数 Technical Data

功率等级 Power Rating	光纤4000W+半导体2000W Fiber 4000W+Diode 2000W	通光孔径 Clear Aperture	光纤35mm, 半导体48mm Fiber 35mm, Diode 48mm
激光波长 Laser Wavelength	光纤1064nm, 半导体915/450nm Fiber 1064nm+Diode 915/450nm	重量 Weight	~9.0kg

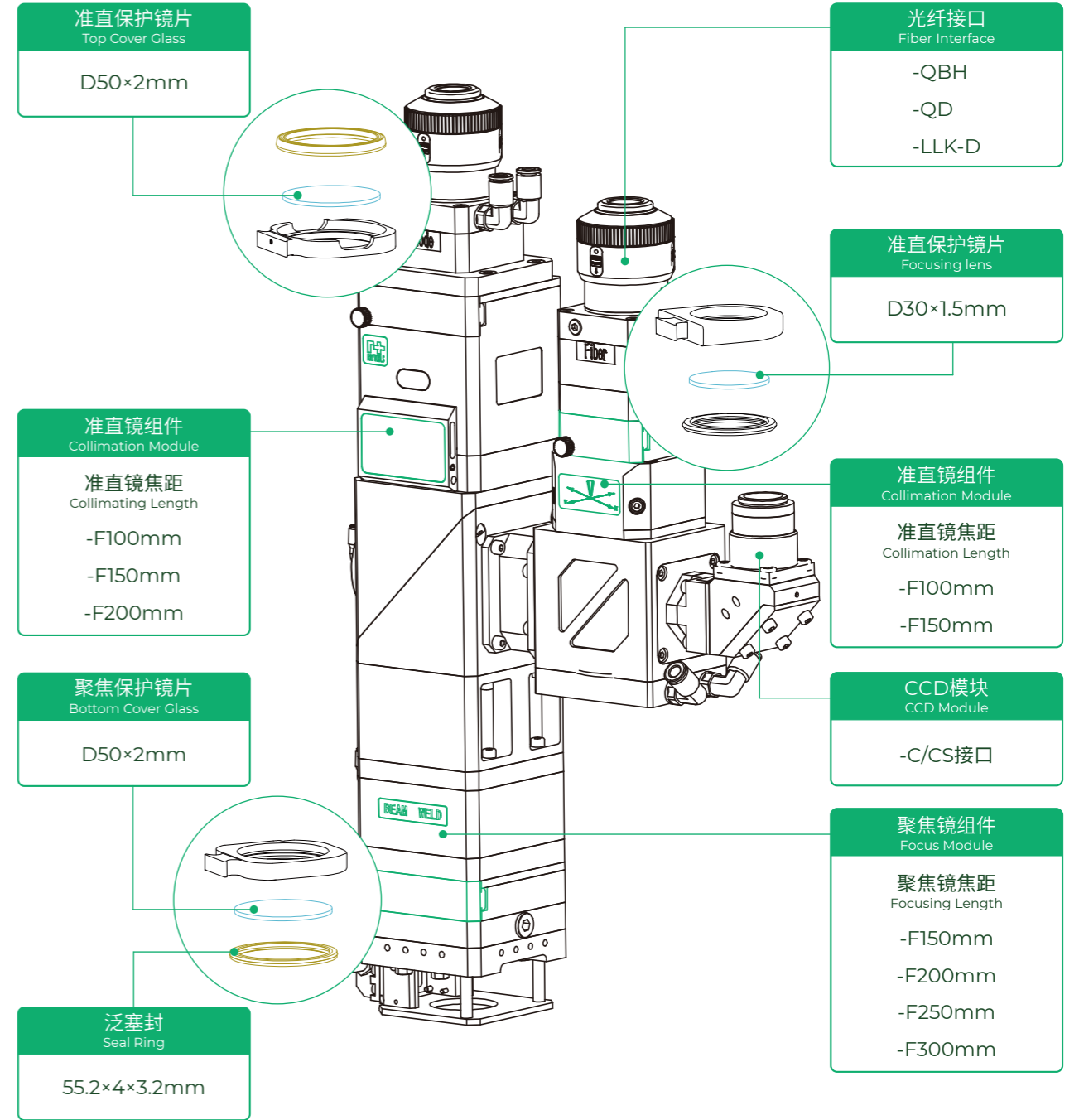

可选末端组件  
Optional Tip Assembly

气刀保护组件  
Air Knife Protection Assembly

可选末端组件  
Optional Tip Assembly

同轴保护组件  
Coaxial Protection Assembly

- F150mm
- F200mm
- F250mm
- F300mm

# BW290-6B

双波段复合摆动焊接头

Dual-wavelength Hybrid Wobble Welding Head

功率等级 **6kW**  
Power Rating



更多信息请扫描二维码  
Scan to get details

## 高功率焊接

High Power Rating

能够承受4kW(光纤)+2kW(半导体)

高功率复合摆动焊接

Dual-wavelength (fiber laser 4kW with wobble feature+ diode 2kW) optics system.

## 焊接效果优异

Excellent Welding Effect

低气孔率、高力学性能、高质量焊缝表面

With low porosity, high mechanical properties and high quality welding surface.

## 丰富的扫描图形

Various Scanning Patterns

连续焊支持连续圆、连续直线、连续8形、连续方形、连续椭圆

Support for continuous circle, continuous square, continuous line, continuous ellipse and continuous 8 type, etc.

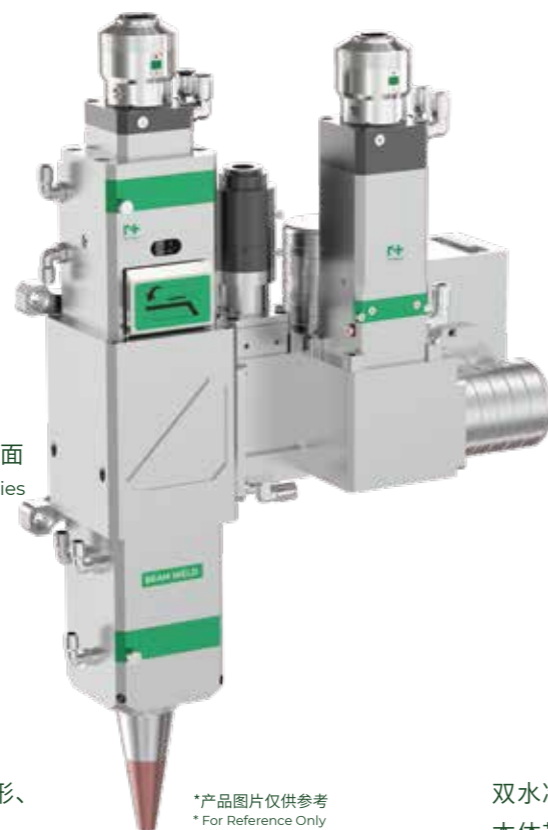

\*产品图片仅供参考  
\* For Reference Only

## 抽屉式镜座

Drawer Type Lens Holder

保护镜片更换快速、简单

Drawer type cover glass holder to facilitate replacement.

## 高度防尘

Excellent Dustproof

牢靠的密封性设计,可以有效避免光学镜片污染,提高使用寿命

Reliable sealing design to avoid contamination to optical lens and prolong the lifespan.

## 高效冷却

Efficient Cooling

双水冷结构设计,保护镜镜座及激光头本体带有水冷接口,延长持续工作时长

Dual water cooling structure with interfaces on both the cover glass holder and the laser head to extend the working duration.

## 技术参数 Technical Data

功率等级 Power Rating	光纤4000W+半导体2000W Fiber 4000W+Diode 2000W	通光孔径 Clear Aperture	光纤30mm, 半导体48mm Fiber 35mm, Diode 48mm
激光波长 Laser Wavelength	光纤1064nm, 半导体915/450nm Fiber 1064nm+Diode 915/450nm	重量 Weight	~12.0kg

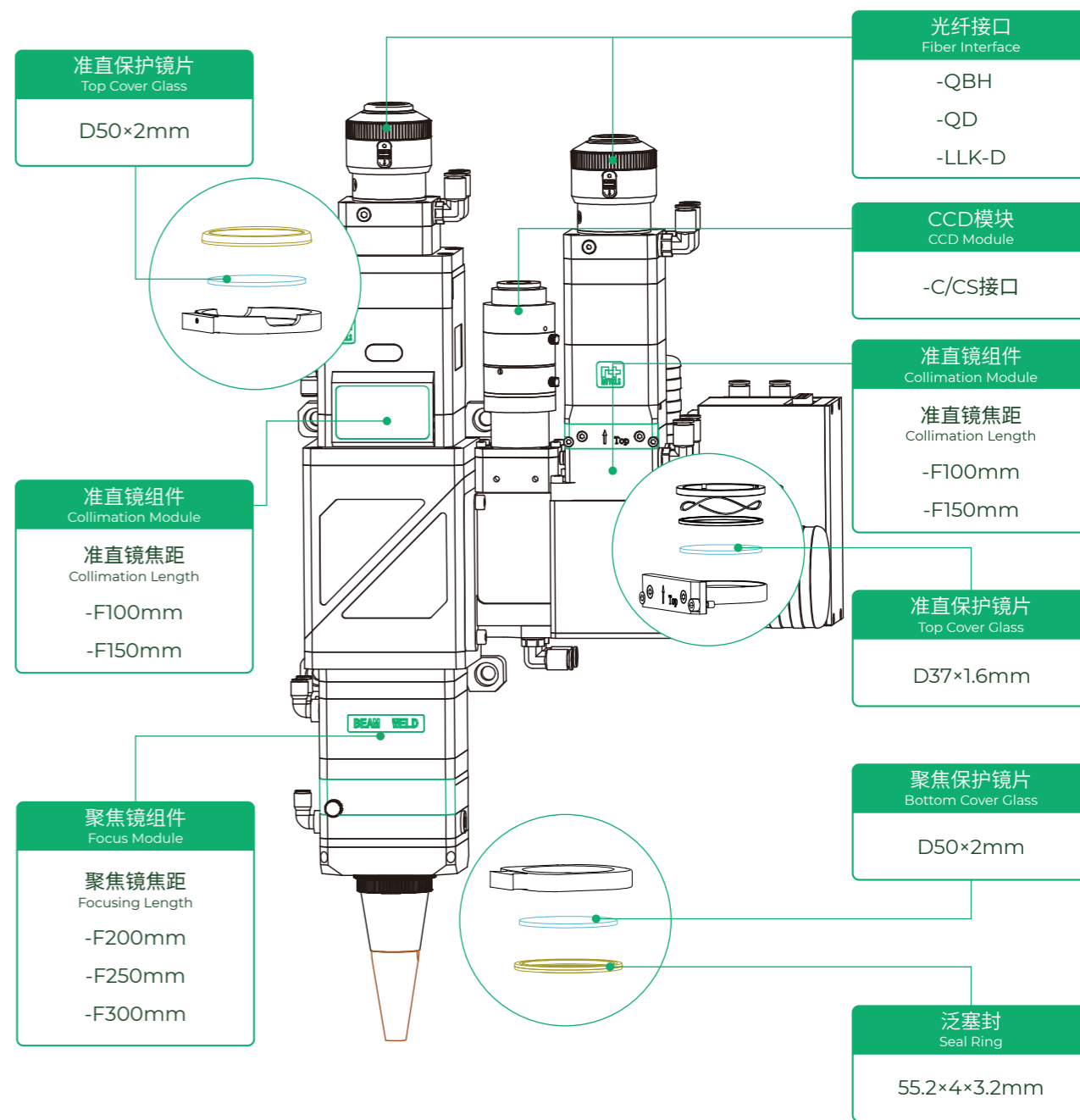

**可选末端组件**  
Optional Tip Assembly

**气刀保护组件**  
Air Knife Protection Assembly

**可选末端组件**  
Optional Tip Assembly

**同轴保护组件**  
Coaxial Protection Assembly

-F200mm  
-F250mm  
-F300mm

# BW290-ZOOM

自动变焦智能焊接/熔覆/淬心头

Smart Auto Zoom Welding/Cladding/Hardening Head

功率等级  
Power Rating **6kW**

自动变焦调节  
Auto Zoom

自动调焦以及光斑大小的调节  
Auto focusing and spot size adjustment.

高度兼容  
High Compatibility

可兼容不同类型的激光器, 可用于焊接、熔覆、淬火于一体  
Compatible with different types of lasers, and can be used for welding, cladding and hardening in one.

高效冷却  
Efficient Cooling

双水冷结构设计, 保护镜镜座及激光头本体带有水冷接口, 延长持续工作时长  
Dual water cooling structure with interfaces on both the cover glass holder and the laser head to extend the working duration.



\*产品图片仅供参考  
\* For Reference Only

## 技术参数 Technical Data

功率等级 Power Rating	6000W
激光波长 Laser Wavelength	1064nm
通光孔径 Clear Aperture	37mm
重量 Weight	~10.0kg

可变圆形光斑示例 Samples of Adjustable Circular Beam Spot				
光纤激光器 Fiber Laser (NA≤0.09)	聚焦F			
光纤芯径 Fiber Core 100um	150mm	0.12mm	←→	0.45mm
	200mm	0.16mm	←→	0.6mm
	250mm	0.2mm	←→	0.75mm
光纤芯径 Fiber Core 200um	150mm	0.24mm	←→	0.9mm
	200mm	0.32mm	←→	1.2mm
	250mm	0.4mm	←→	1.5mm
光纤芯径 Fiber Core 400um	150mm	0.48mm	←→	1.8mm
	200mm	0.64mm	←→	2.4mm
	250mm	0.8mm	←→	3mm

可变圆形光斑示例 Samples of Adjustable Circular Beam Spot				
半导体激光器 Diode Laser (NA≤0.22)	聚焦F			
光纤芯径 Fiber Core 200um	150mm	0.408mm	←→	0.9mm
	200mm	0.544mm	←→	1.2mm
	250mm	0.64mm	←→	1.5mm
光纤芯径 Fiber Core 400um	150mm	0.816mm	←→	1.8mm
	200mm	1.088mm	←→	2.4mm
	250mm	1.28mm	←→	3mm



更多信息请扫描二维码  
Scan to get details

## 抽屉式镜座

Drawer Type Lens Holder

保护镜片更换快速、简单  
Drawer type cover glass holder to facilitate replacement.

## 智能监测

Smart Monitoring

可实时监测保护镜的工作温度  
Real-time monitoring of the operating temperature of cover glass.

## 扩展模块丰富

Rich Function Expanding

可扩展焊缝跟踪或寻位功能等模块, 易于实现自动化焊接  
Modules like seam tracking and positioning are optional for expanding of function. Make it easy to realize auto welding.

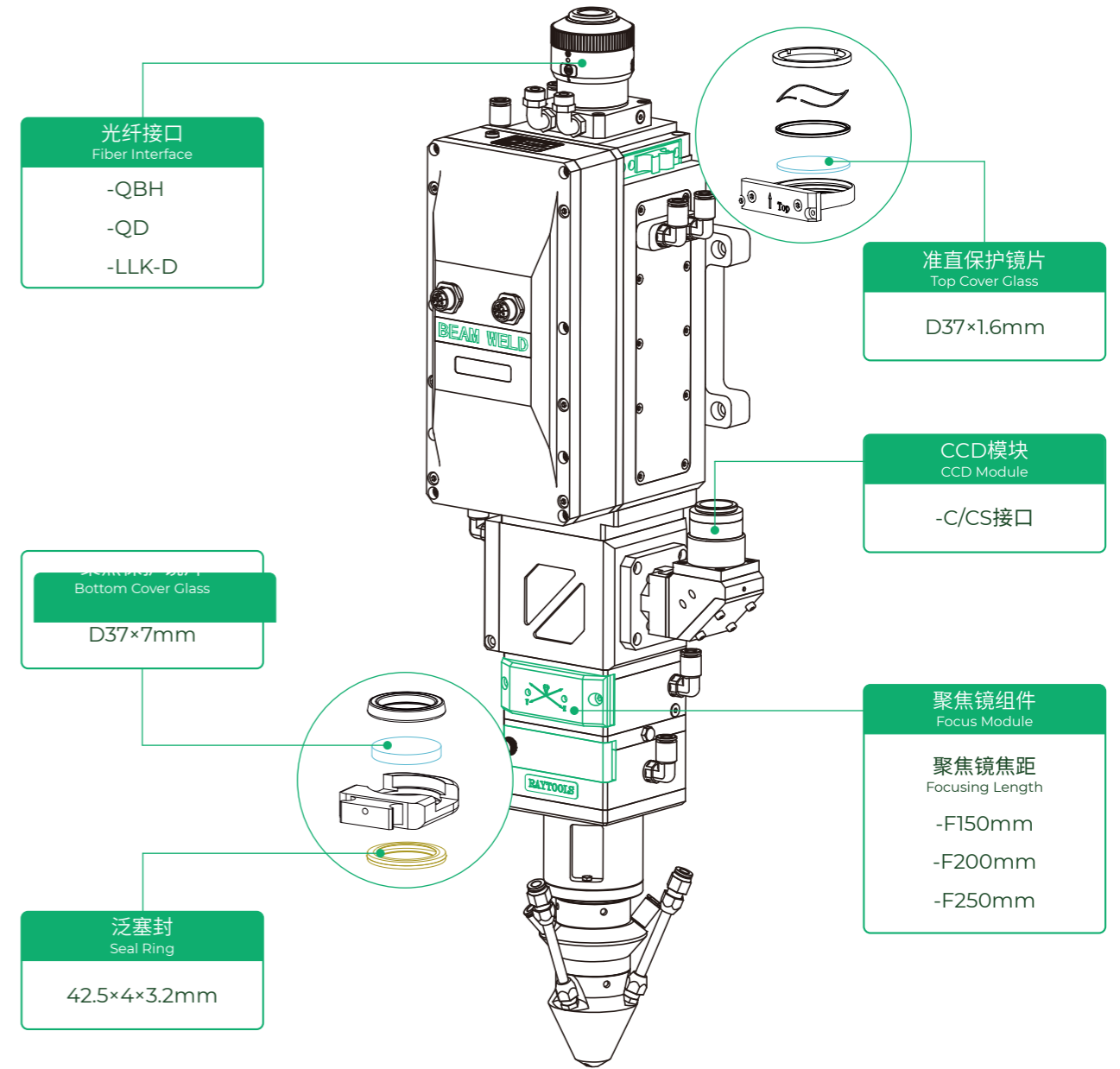

可选末端组件  
Optional Tip Assembly

气刀保护组件  
Air Knife Protection Assembly

可选末端组件  
Optional Tip Assembly

熔覆喷嘴  
Cladding Nozzle

- 三路送粉喷嘴  
3-way Powder Feeding Nozzle
- 同轴环形送粉喷嘴  
Coaxial Annular Powder Feeding Nozzle

# BW310

## 双焦点旋转焊接头

Dual-spot Welding Head

功率等级 **4kW**  
Power Rating



更多信息请扫描二维码  
Scan to get details

### 间隙容忍度高

High Tolerance to Welding Gap

焊接间隙较大时, 调节光斑间距可显著改善焊接质量, 焊缝形貌更美观

Adjustable distance between dual spots to obviously improve the welding quality and seam shape when the welding gap is relatively big.

### 光斑间距与位置可调

Adjustable Spot Distance & Direction

通过传动机构可以实现光斑方向的调节, 此外, 通过精密调节机构, 能够实现光斑距离的调节, 满足不同焊缝焊接需求

The direction of spot is able to be adjusted via transmission mechanism. The distance between the spots could be adjusted via precision adjusting mechanism to cater for various applications.

### 光斑能量分布可调

Adjustable Energy Distribution of Beam Spot

光斑能量分布调节范围:

23%:77% — 77%:23%

The energy distribution of beam spot is adjustable within below range:  
23%: 77% — 77%: 23%

## 技术参数 Technical Data

功率等级 Power Rating	4000W
激光波长 Laser Wavelength	1064nm
回旋范围 Rotation Range	0-360°

通光孔径 Clear Aperture	37mm
重量 Weight	~8.5kg



\*产品图片仅供参考  
\* For Reference Only

### 特种焊接更有利

Favorable to Special Welding

针对不等厚拼焊、异种材料焊、镀锌板焊接等特殊焊接, 效果更稳定, 质量更优异  
Particularly applicable to butt-welding of unequal thickness, welding of unequal material, and welding of galvanized steel with stability and high quality.

### 扩展模块丰富

Rich Function Expanding

可扩展焊缝跟踪或寻位功能等模块, 易于实现自动化焊接  
Modules like seam tracking and positioning are optional for expanding of function. Make it easy to realize auto welding.

### 优质的气流设计

High Quality Gas Circuit

旁轴保护喷嘴和气刀采用平滑高效的流体结构设计, 能获得优质的熔池保护效果与焊渣吹除效果  
Efficient fluid structure design of the side-blow nozzle and air knife assembly for the excellent effect of slag blowing and protection to the melting pool.

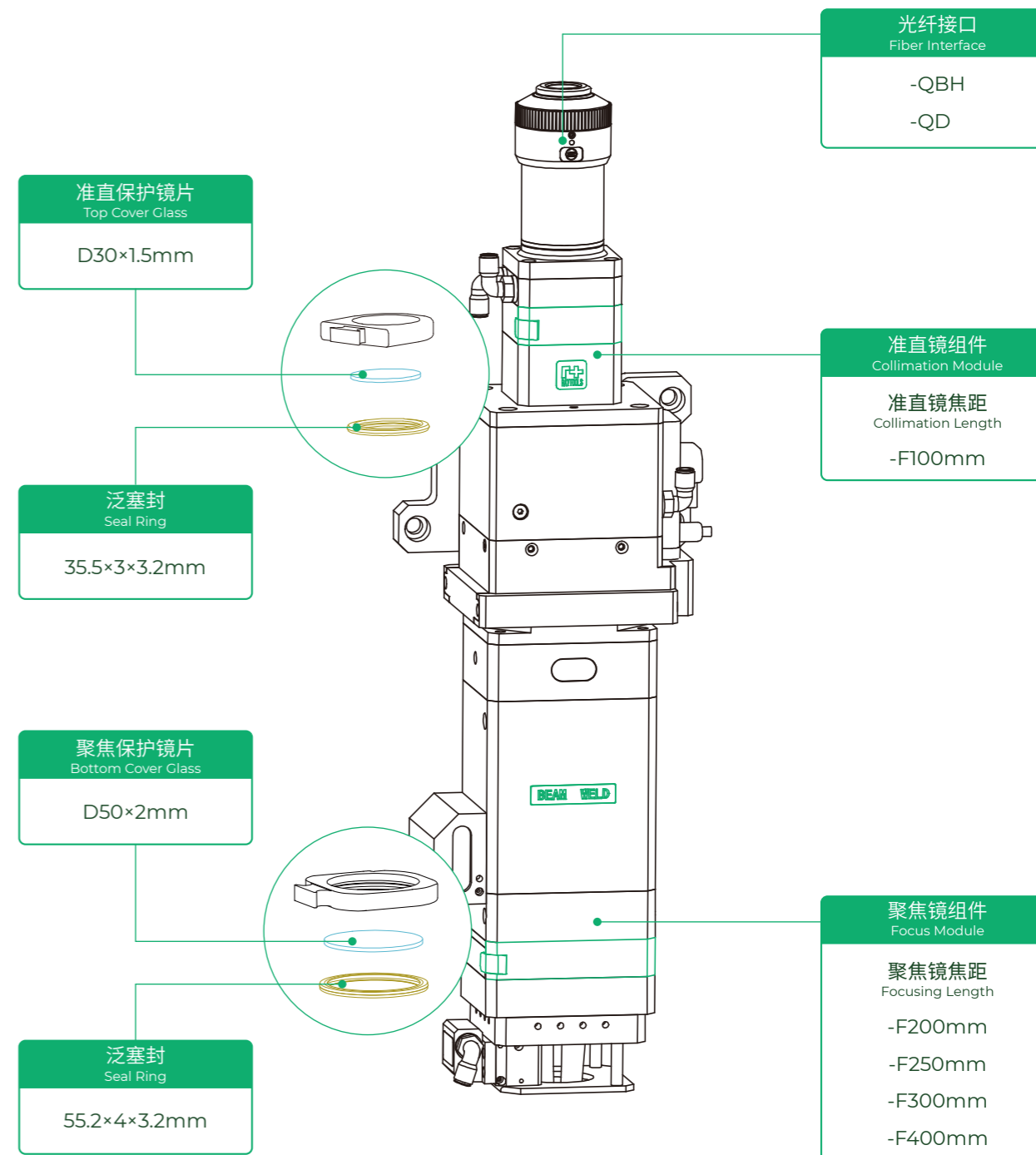



# BW12K/BW20K

透射式激光焊接头

Laser Welding Head - Transmission Type

功率等级

Power Rating

12kW/20kW

更多信息请扫描二维码

Scan to get details



## 高功率焊接

High Power Rating

最高能够承受12kW/20kW高功率焊接

The maximum power is up to 12kW/20kW to meet the market demand of high power welding.

## 焊接效果优异

Excellent Welding Effect

低气孔率、高力学性能、高质量焊缝表面

With low porosity, high mechanical properties and high quality welding surface.

## 智能监测

Smart Monitoring

可实时监测保护镜的工作温度

Real-time monitoring of the operating temperature of cover glass.



\*产品图片仅供参考  
\* For Reference Only

## 抽屉式镜座

Drawer Type Lens Holder

保护镜片更换快速、简单，

3片保护镜片，高效保护准直、聚焦镜片

Drawer type cover glass holder to facilitate replacement. 3 cover glasses to protect focus & collimation lens.

## 高度防尘

Excellent Dustproof

牢靠的密封性设计，可以有效避免光学镜片污染，提高使用寿命

Reliable sealing design to avoid contamination to optical lens and prolong the lifespan.

## 高效冷却

Efficient Cooling

双水冷结构设计，保护镜镜座及激光头本体带有水冷接口，延长持续工作时长

Dual water cooling structure with interfaces on both the cover glass holder and the laser head to extend the working duration.

## 技术参数 Technical Data

功率等级 Power Rating	12000W/20000W	通光孔径 Clear Aperture	48mm
激光波长 Laser Wavelength	光纤1064nm Fiber 1064nm	重量 Weight	~5.0kg

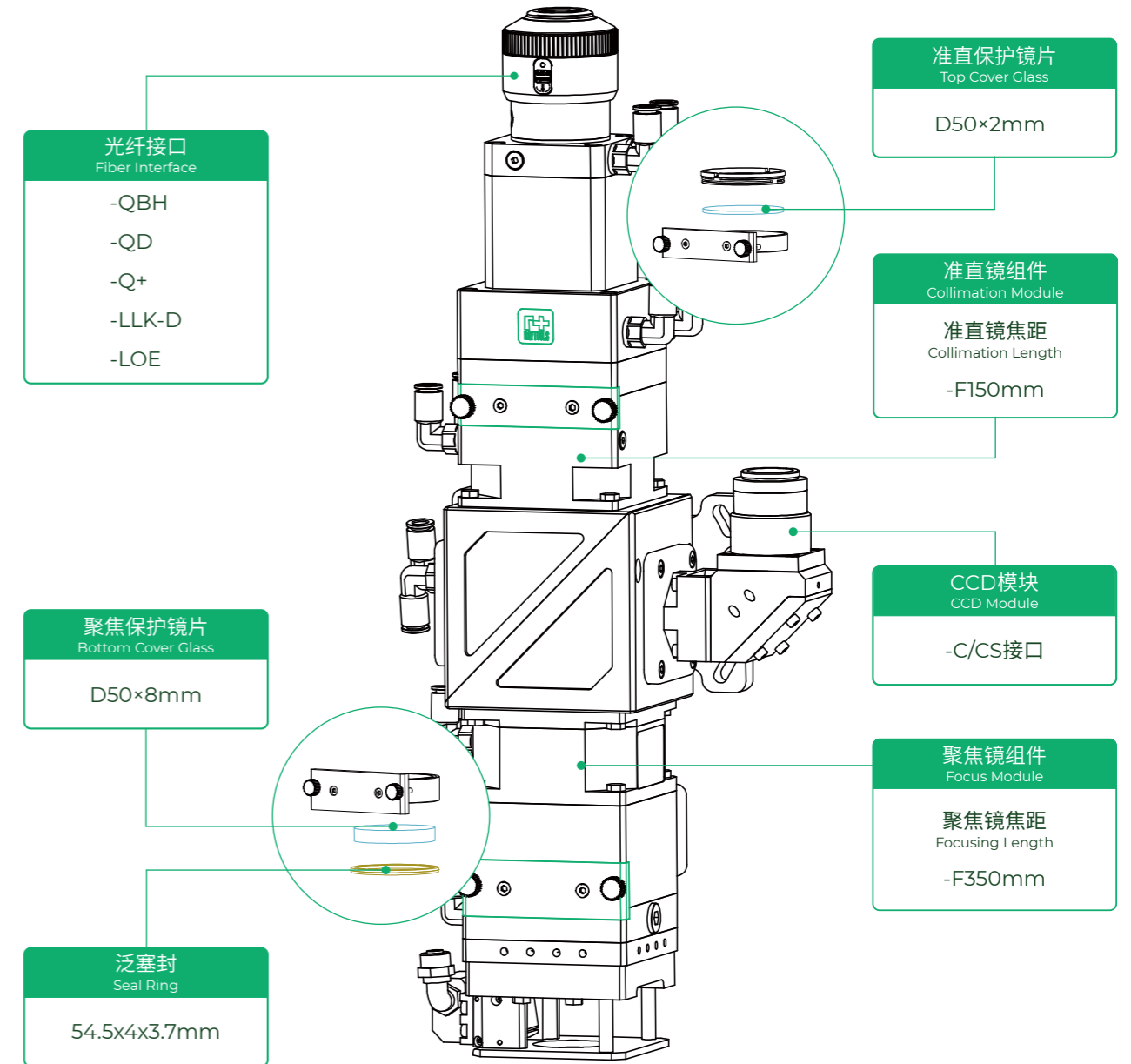

**可选末端组件**  
Optional Tip Assembly

**气刀保护组件**  
Air Knife Protection Assembly

**可选末端组件**  
Optional Tip Assembly

**同轴保护组件**  
Coaxial Protection Assembly

-F350mm

# BF320

同轴搅拌焊接头  
Coaxial Wobble Welding Head

功率等级 3kW  
Power Rating



更多信息请扫描二维码  
Scan to get details

## 优异的焊接质量

Excellent Welding Quality

提高焊缝表面平滑度, 减小焊接内部气孔, 提高焊缝强度; 减少在焊接过程中的飞溅  
Improve the smoothness of the weld surface and the strength of the weld seam; reduce the porosity and weld spatter.

## 图形可调

Adjustable Graphics

画圆图形大小可调, 频率可调  
Continuous wobbling path: circle, and its size and frequency are adjustable.



\*产品图片仅供参考  
\* For Reference Only

## 抽屉式镜座

Drawer Type Lens Holder

保护镜片更换快速、简单  
Drawer type cover glass holder to facilitate replacement.

## 高效水冷

Efficient Water Cooling

整体循环水冷, 能够在高功率下长时间稳定地工作  
Integral water cooling circuit for working long and stable at high power.

## 高度防尘

Excellent Dustproof

牢靠的密封性设计, 提高使用寿命  
Reliable sealing design to prolong the lifespan.

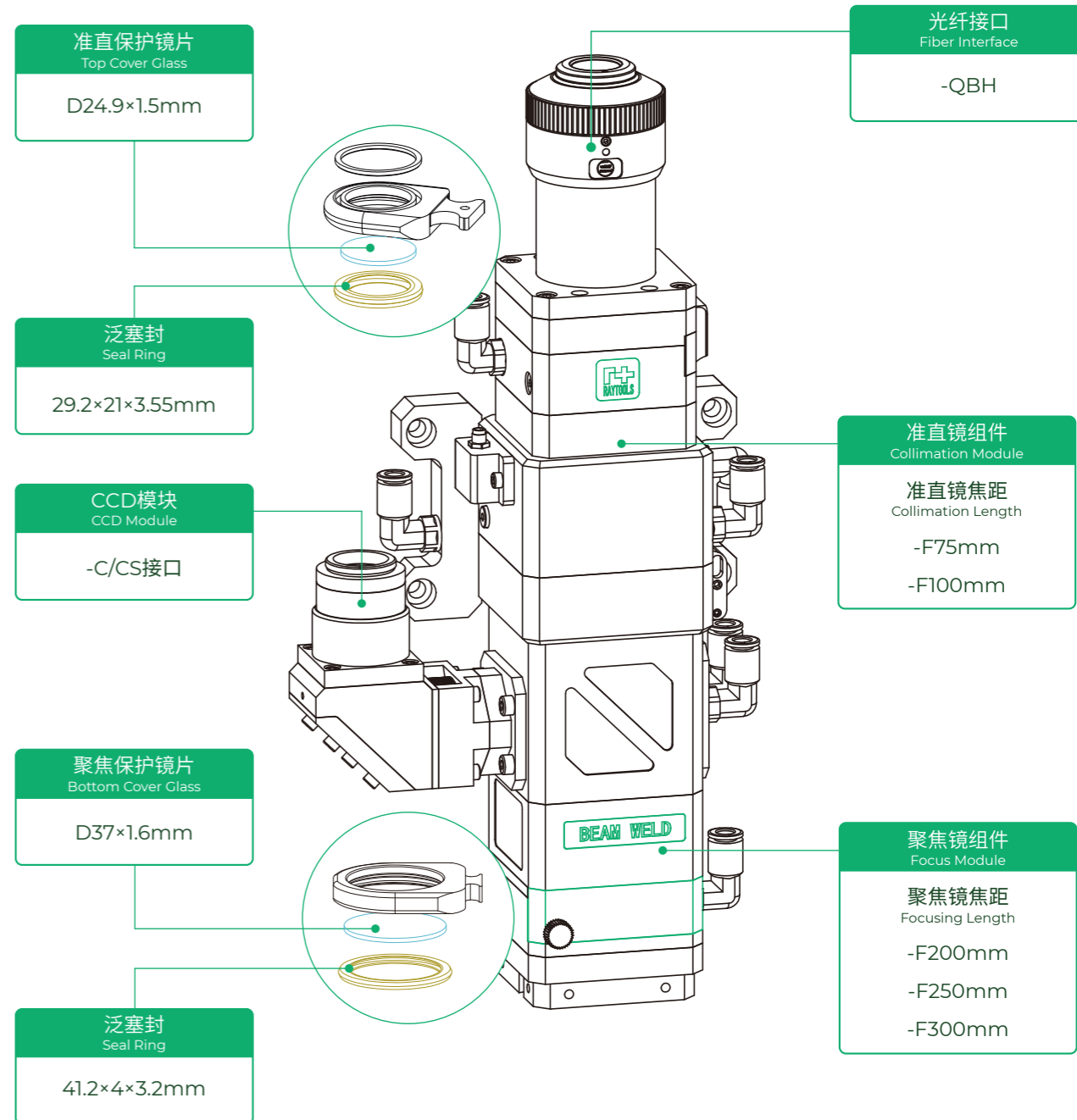

## 技术参数 Technical Data

功率等级 Power Rating	3000W
画圆范围 Circle Drawing Range	0-4mm(F250mm)
画圆频率 Circle Frequency	0-200Hz

激光波长 Laser Wavelength	1064nm
通光孔径 Clear Aperture	26mm
重量 Weight	~4.5kg

可选末端组件  
Optional Tip Assembly

气刀保护组件  
Air Knife Protection Assembly

可选末端组件  
Optional Tip Assembly

同轴保护组件  
Coaxial Protection Assembly

- F200mm
- F250mm
- F300mm

# BF02K-MINI

摆动焊接头

Wobble Welding Head

功率等级 **2kW**  
Power Rating



更多信息请扫描二维码  
Scan to get details

## 样式新颖

Innovative Style

重量轻, 体积小, 结构紧凑, 操作简单  
Light weight, small size, compact structure, and easy operation.

## 多样摆动图形

Various Graphics

8种焊接图形, 适用不同的工艺需求  
8 welding patterns to meet different process requirements.

## 优化设计

Optimal Design

内部密封设计, 高度防尘  
Sealing design for internal structure, with highly dust-proof and slag-proof function, to manufacture products with stable and reliable performance.



\*产品图片仅供参考  
\* For Reference Only

## 稳定便捷

Stable and Convenient

驱控一体化, 抗干扰能力强,  
外部接线简单  
Supporting drive & control, with strong anti-interference ability and simple external wiring structure.

## 兼容性强

High Compatibility

自带显示屏控制, 可脱机,  
PC控制等工作模式。  
Self-contained display screen control function, supporting offline, PC control and other working modes.

## 工艺优势

Excellent Dustproof

低气孔率, 高力学性能, 高质量焊接表面  
With low porosity, high mechanical properties and high quality welding surface.

## 技术参数 Technical Data

功率等级 Power Rating	2000W
摆动幅度 Wobble Size	0-5mm
焊接保护气 Welding Gas	15-25L/min

激光波长 Laser Wavelength	1070±10nm
通光孔径 Clear Aperture	14mm
重量 Weight	~2.0kg

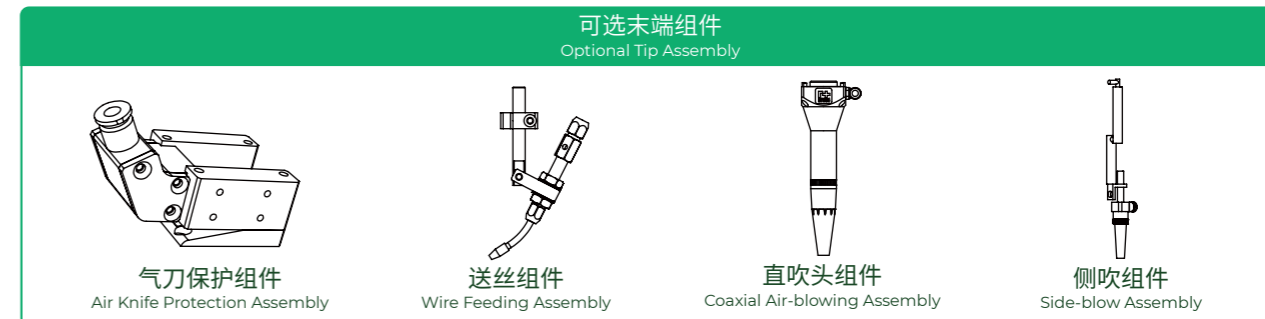
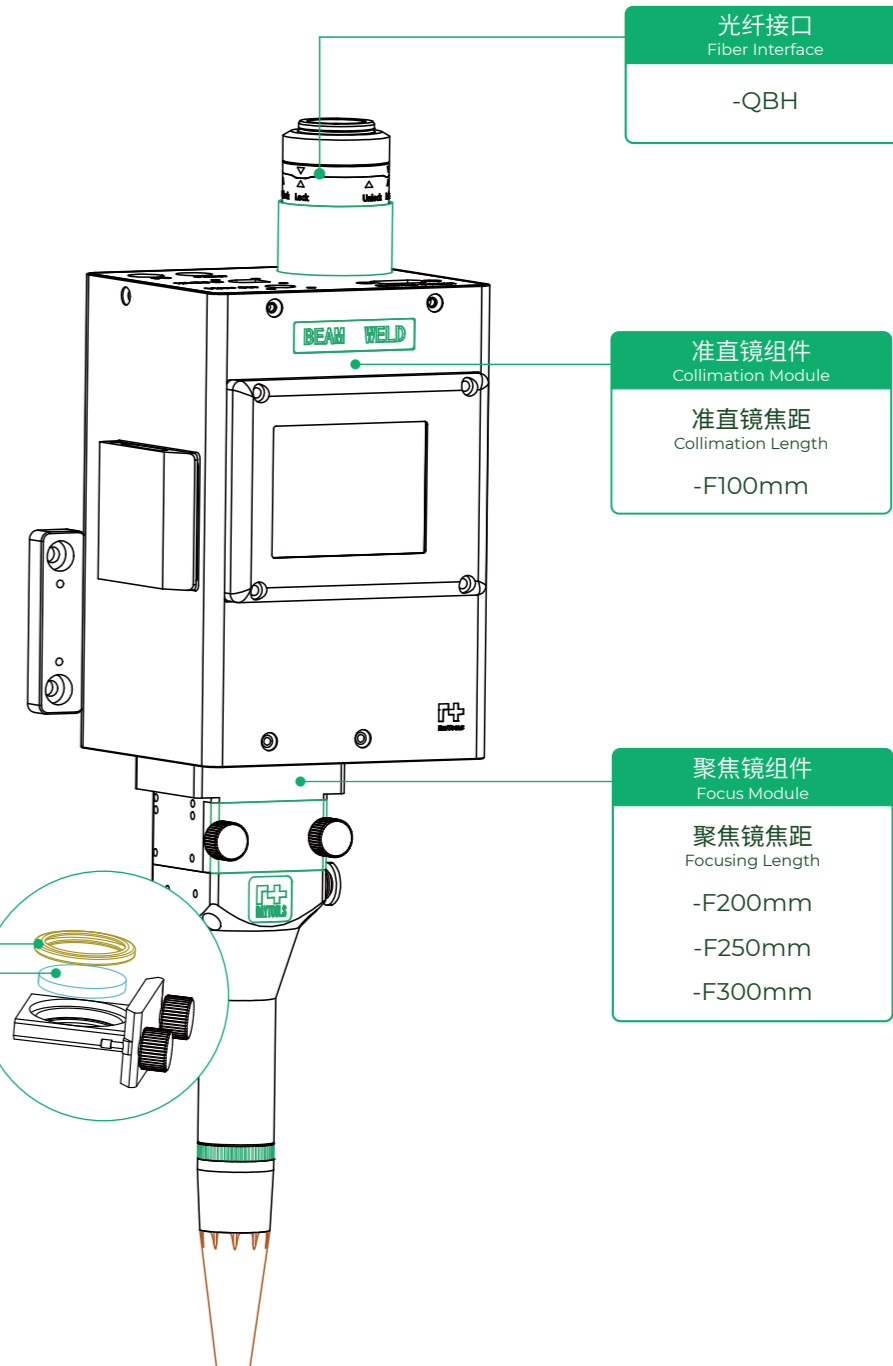

# BF03S

## 摆动焊接头

Wobble Welding Head

功率等级  
Power Rating **3kW**



更多信息请扫描二维码  
Scan to get details

## 模式丰富

Various Mode

显示屏控制, 兼容脱机, PC控制等工作模式  
Working modes include: display control, offline compatible, PC control, etc.

## 工艺特点

Technological Features

8种摆动图形, 适用不同的工艺需求  
With 8 different kinds of graphics for wobble welding, applicable to various process requirements.

## 优化设计

Optimized Design

双保护窗设计, 防尘防渣设计,  
高效水冷, 稳定可靠

Dual cover glass design to proof dust and slag, which makes the product to be stable and reliable.



\*产品图片仅供参考  
\* For Reference Only

## 配置丰富

Various Configuration

提供相机、工业镜头、监视器和蓝光光源  
Optional configurations includes: camera, industrial lens, monitor and blue laser.

## 优质光学方案

Excellent Optical Solution

针对监视特别优化的光学方案,  
让焊接过程清晰可见  
Monitoring of optimized optical processing solution enables the welding process clear to see.

## 稳定便捷

Stable and Convenient

驱控一体化, 抗干扰能力强, 外部接线简单  
Integrated motor and controller with strong anti-interference ability and simple external wiring.

## 技术参数 Technical Data

功率等级 Power Rating	3000W
X轴摆动幅度 X-Axis Wobble Size	0-5mm
Y轴摆动幅度 Y-Axis Wobble Size	0-5mm

通光孔径 Clear Aperture	20mm
摆动频率 Wobble Frequency	0-500Hz
重量 Weight	~3.0kg

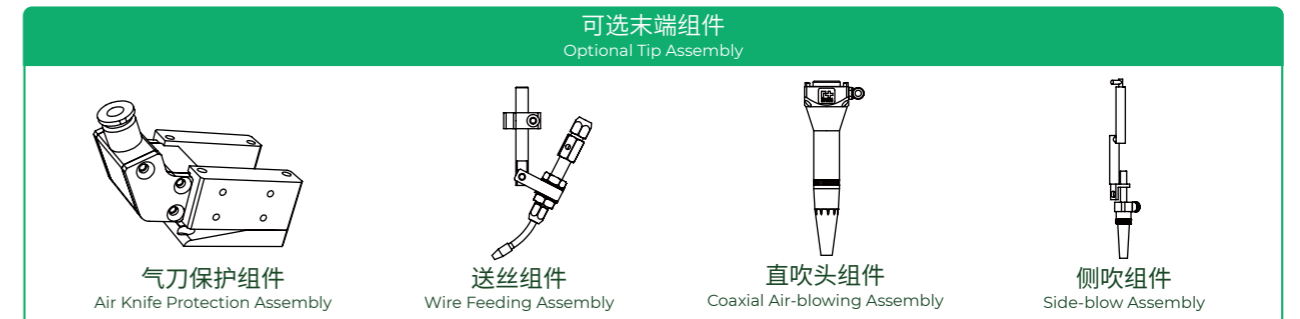
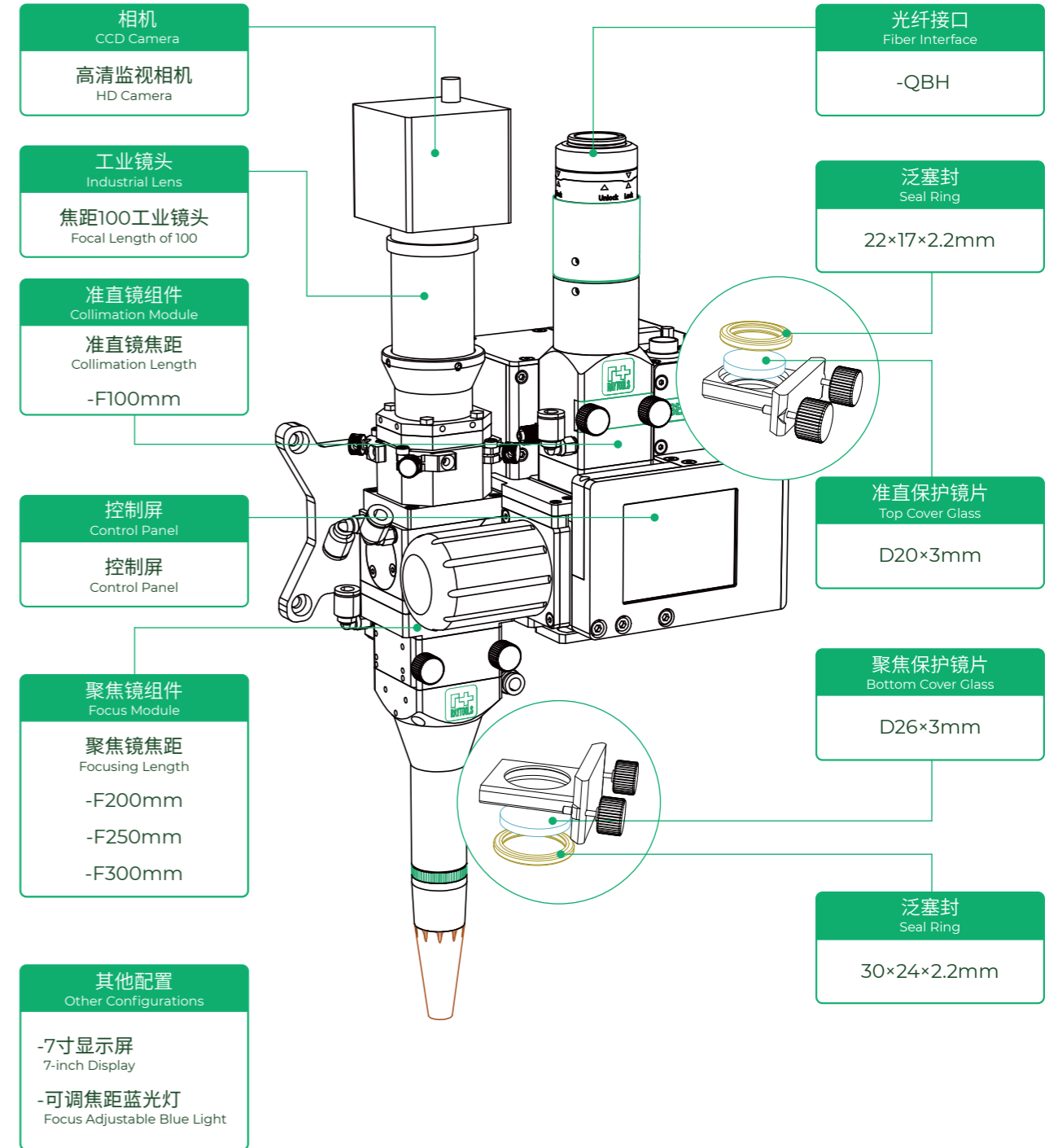



# BF330-2F

摆动焊接头

Wobble Welding Head

功率等级  
Power Rating **2kW**



更多信息请扫描二维码  
Scan to get details

## 优异的焊接质量

Excellent Welding Quality

大焊缝、低气孔率、高力学性能、高表面质量

With large welding seam, low porosity, high mechanical properties and high quality welding surface.



\*产品图片仅供参考  
\* For Reference Only

## 轻型中低功率扫描焊接头

Light-duty Medium and Low Power Galvo Welding Head

最高激光承受功率2kW，  
整机重量约5.5kg

The maximum power rating is 2kW and the machine weight is about 5.5kg.

## 丰富的模块选择

Rich Function Expanding

可适配旁轴线光源实现TCP校准，旁轴蓝光点光源实现CCD图像照明，位置传感器实现寻位跟踪，温度传感器实现等熔深焊接，旁轴送丝机构实现填丝焊

Optional expansion modules include: paraxonic light source for TCP collimator, paraxonic blue laser for CCD image lighting, position sensor for tracking and positioning, temperature sensor for deep penetration welding and paraxonic wire feeder for wire feed welding.

## 丰富的扫描图形

Various Scanning Patterns

连续焊支持圆形、方形、直线、椭圆、C形、S形、8形

Support for circle, square, straight line, ellipse and C-shape, S-shape, figure 8 in continuous welding.

## 技术参数 Technical Data

功率等级 Power Rating	2000W
激光波长 Laser Wavelength	1064nm
扫描线速度 Scan Speed	≤2800mm/s

通光孔径 Clear Aperture	24mm
重量 Weight	~5.5kg

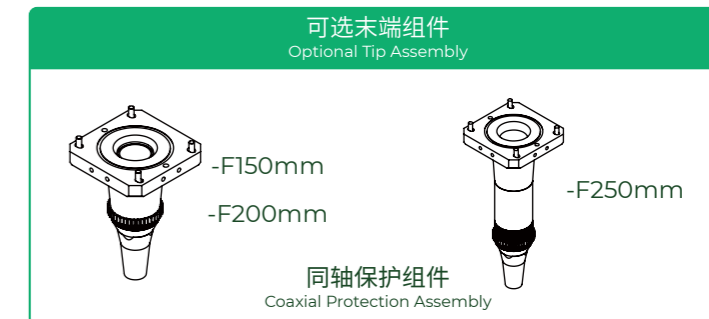
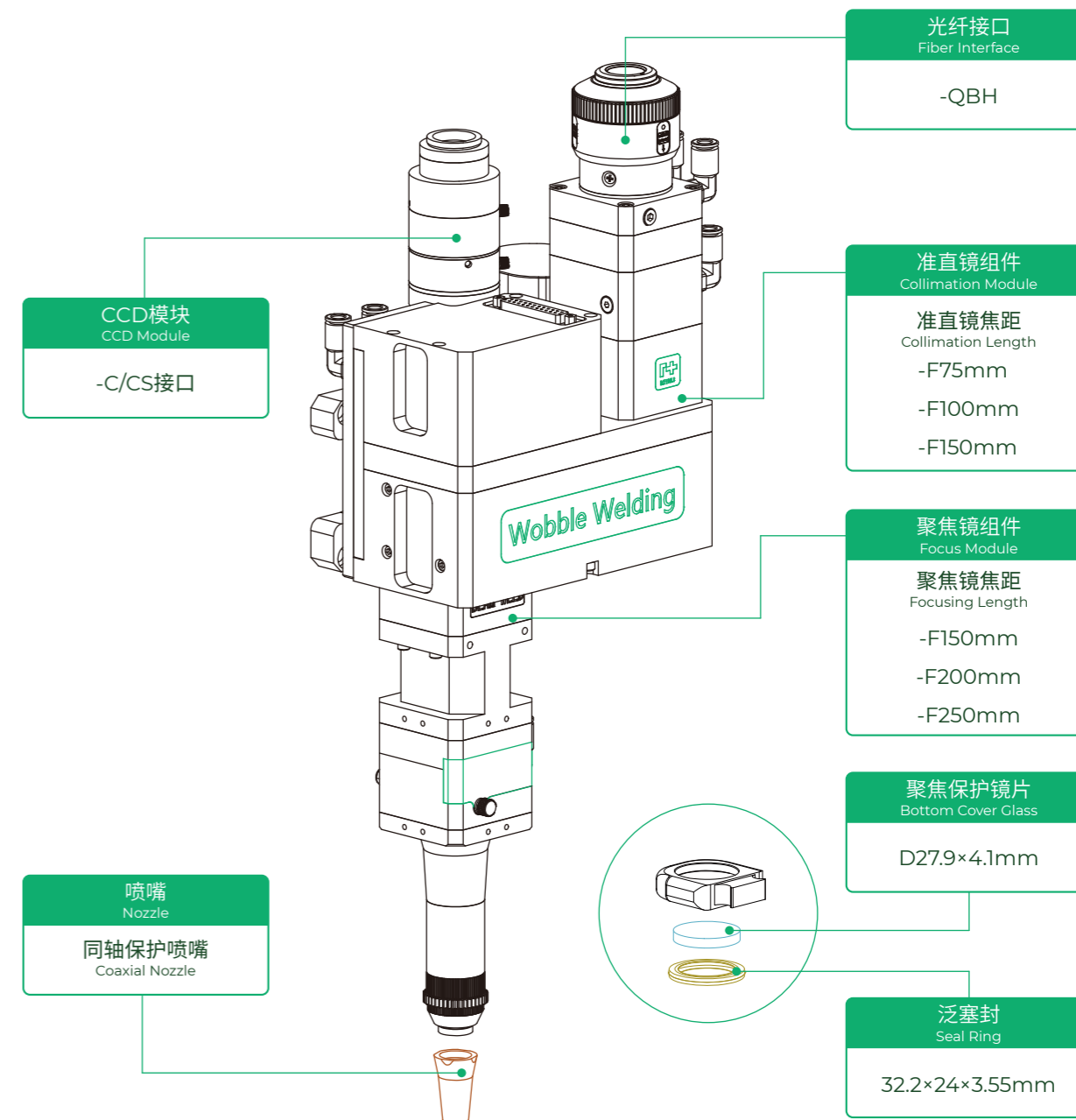

# BF330-4F

摆动焊接头

Wobble Welding Head

功率等级 **4kW**  
Power Rating



更多信息请扫描二维码  
Scan to get details

高承受功率

High Power Rating

最大可承受功率高达4kW, 满足中高功率焊接市场需求

The maximum power rating is up to 4kW to meet the market demand of medium and high power welding.



\*产品图片仅供参考  
\* For Reference Only

工艺优点

Technological Advantages

增加熔宽

增加间隙适应性

减少焊缝缺陷

优异的成型效果

Increase the seam width and the adaptability of welding gap; reduce seam defects, for the excellent welding effect.

易于实现自动化

Easy to Automate

可拓展焊缝跟踪或寻位功能,

易于实现机器人自动化集成

Seam tracking and positioning are optional for expanding function, which makes it easy to realize the integrated robotic automation.

优质的气流设计

High Quality Gas Circuit

同轴、旁轴保护喷嘴和气刀采用平滑高效的流体结构设计, 能获得优质的熔池保护效果与焊渣吹除效果

Efficient fluid structure design of the coaxial nozzle, side-blow nozzle and air knife assembly for the excellent effect of slag blowing and protection to the melting pool.

扫描频率高, 运动路径多

High Scanning Frequency and Diverse Wobble Paths

优化的光学结构及运动机构, 不同的搅拌路径和高搅拌频率来满足不同高速搅拌焊接的需求

With optimized optical structure and motion mechanism, use different wobble paths and high scanning frequency to meet different requirements of high speed wobble welding.

## 技术参数 Technical Data

功率等级 Power Rating	4000W
激光波长 Laser Wavelength	1064nm
扫描线速度 Scan Speed	≤2800mm/s

通光孔径 Clear Aperture	30mm
重量 Weight	~5.8kg

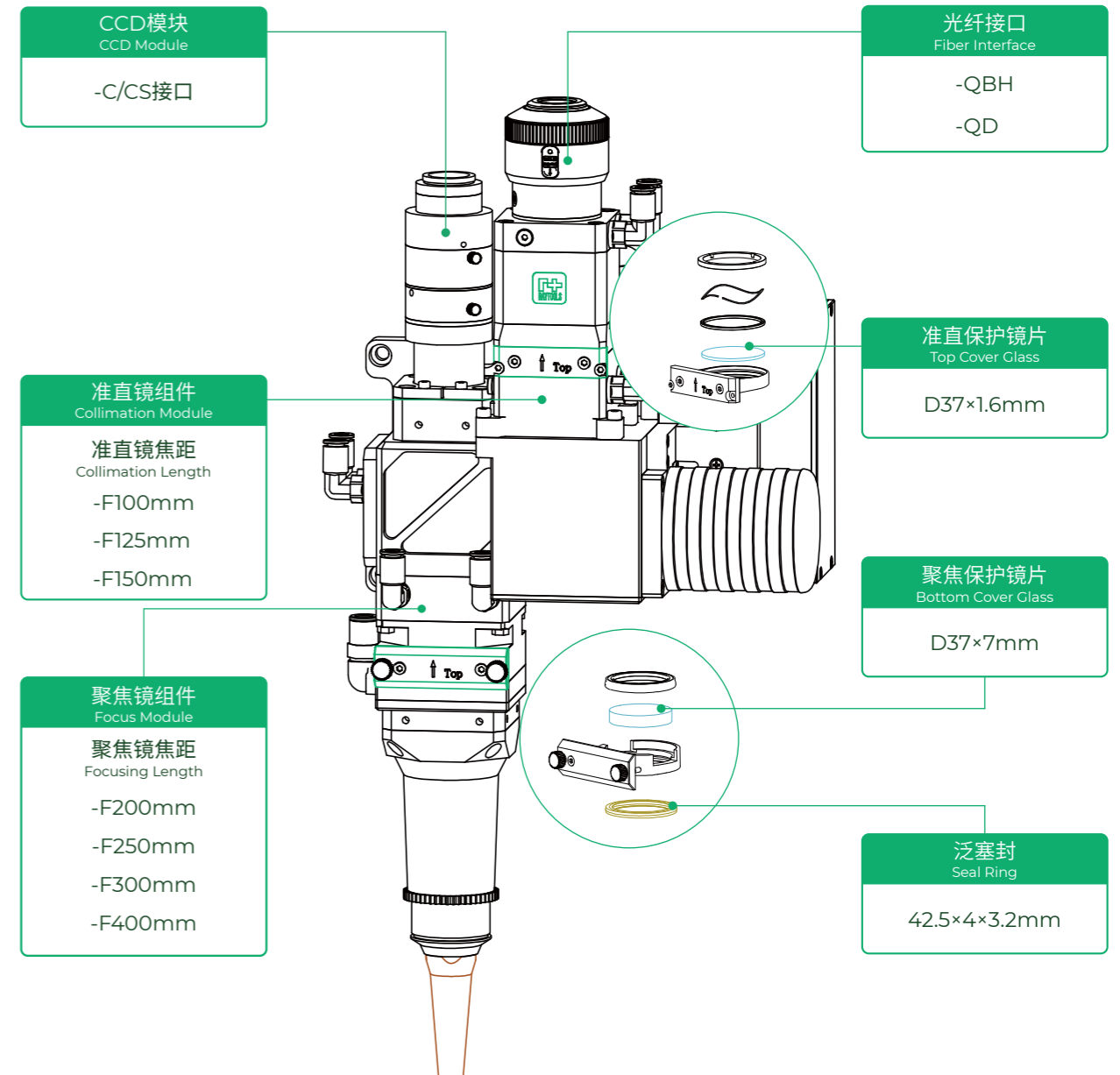

**可选末端组件**  
Optional Tip Assembly

**长焦气刀保护组件**  
Air Knife Protection Assembly-Long Focal

**可选末端组件**  
Optional Tip Assembly

-F200mm  
-F250mm  
-F300mm  
-F400mm

**同轴保护组件**  
Coaxial Protection Assembly

# BF330-6F

摆动焊接头

Wobble Welding Head

功率等级

Power Rating

6kW



更多信息请扫描二维码  
Scan to get details

高功率焊接

High Power Rating

最高能够承受6kW高功率摆动焊接  
The maximum power is up to 6kW to meet the market demand of high power welding.

优异的焊接质量

Excellent Welding Quality

低气孔率、高力学性能、高质量焊缝表面

With low porosity, high mechanical properties and high quality welding surface.

丰富的扫描图形

Various Scanning Patterns

连续焊支持圆形、方形、直线、椭圆、C形、S形、8形

Support for circle, square, straight line, ellipse and C-shape, S-shape, figure 8 in continuous welding.



\*产品图片仅供参考  
\* For Reference Only

扩展模块丰富

Rich Function Expanding

可扩展温度传感器、焊缝跟踪或寻位等功能模块，易于实现自动化焊接

Modules like temperature sensor, seam tracking and positioning are optional for expanding of function. Make it easy to realize auto welding.

抽屉式镜座

Drawer Type Lens Holder

保护镜片更换快速、简单

Drawer type cover glass holder to facilitate replacement.

高效水冷

Efficient Water Cooling

整体循环水冷，能够在高功率下长时间稳定地工作

Integral water cooling circuit to ensure stable and long work at high power.

高度防尘

Excellent Dustproof

牢靠的密封性设计，提高使用寿命

Reliable sealing design to prolong the lifespan.

## 技术参数 Technical Data

功率等级 Power Rating	6000W
激光波长 Laser Wavelength	1064nm
扫描线速度 Scan Speed	≤2800mm/s

通光孔径 Clear Aperture	30mm
重量 Weight	~8.5kg

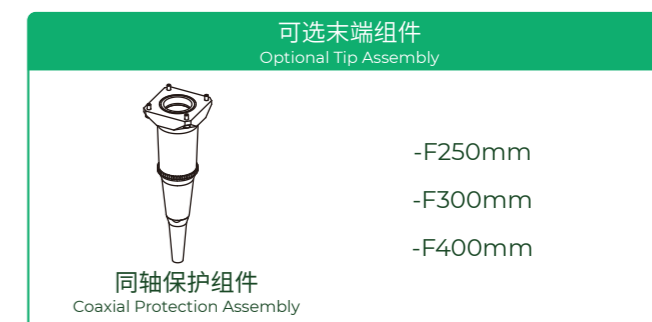
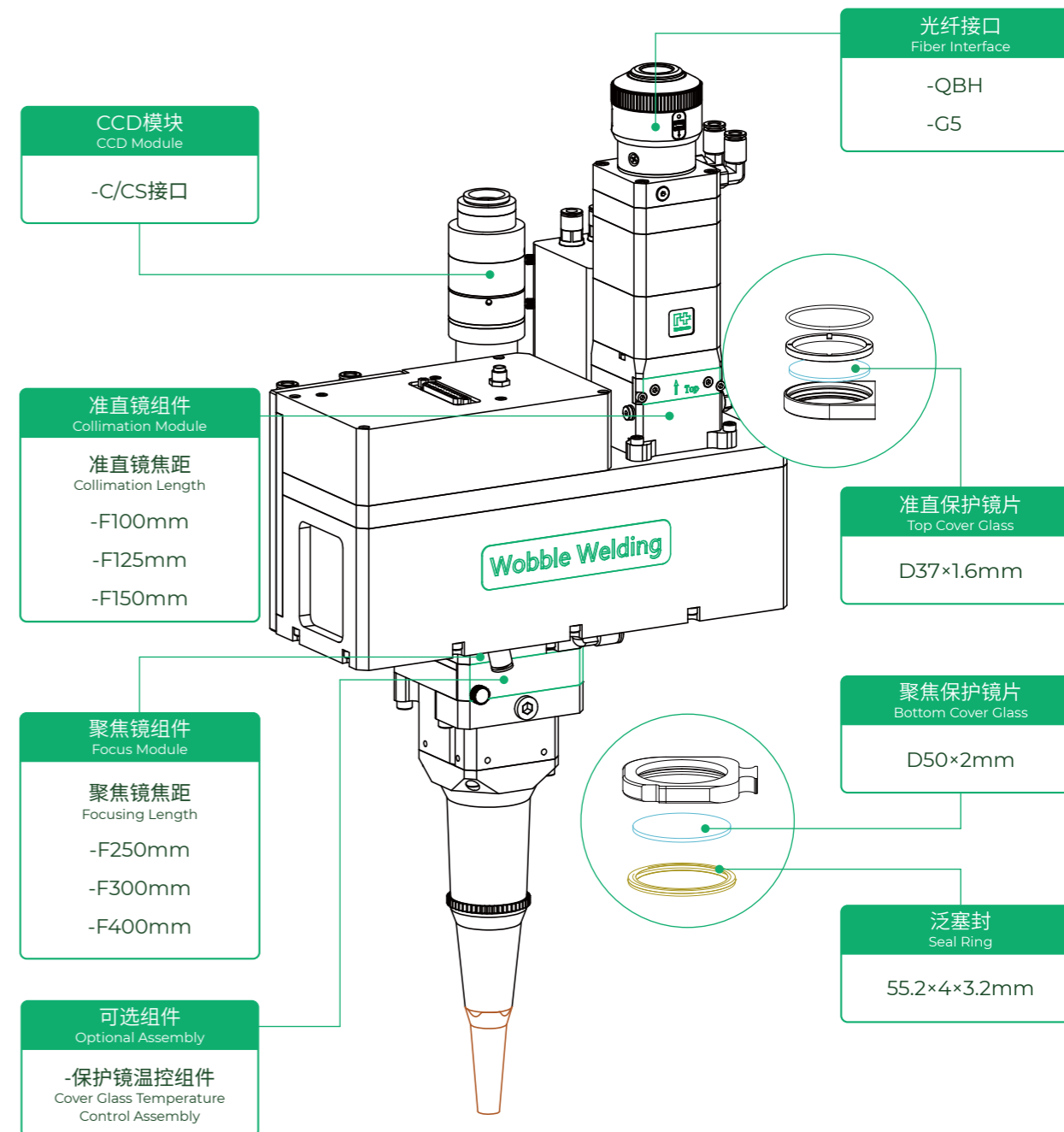

# BF12K

## 摆动焊接头

Wobble Welding Head

功率等级  
Power Rating **12kW**



更多信息请扫描二维码  
Scan to get details

## 高功率焊接

High Power Rating

最高能够承受12kW高功率摆动焊接  
The maximum power is up to 12kW to meet the market demand of high power welding.

## 优异的焊接质量

Excellent Welding Quality

低气孔率、高力学性能、高质量焊缝表面  
With low porosity, high mechanical properties and high quality welding surface.

## 丰富的扫描图形

Various Scanning Patterns

连续焊支持圆形、方形、直线、椭圆、C形、S形、8形

Support for circle, square, straight line, ellipse and C-shape, S-shape, figure 8 in continuous welding.

## 智能监测

Smart Monitoring

可实时监测保护镜的工作温度  
Real-time monitoring of the operating temperature of cover glass.

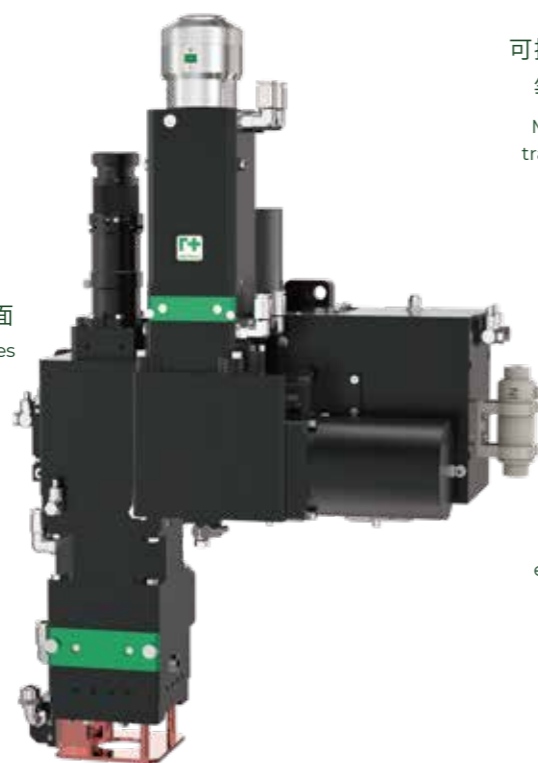

\*产品图片仅供参考  
\* For Reference Only

## 扩展模块丰富

Rich Function Expanding

可扩展温度传感器、焊缝跟踪或寻位等功能模块, 易于实现自动化焊接  
Modules like temperature sensor, seam tracking and positioning are optional for expanding of function. Make it easy to realize auto welding.

## 高效冷却

Efficient Water Cooling

内部振镜片使用高效气冷结构, 保证高效稳定焊接

The internal vibrating lens uses an efficient air cooling structure to ensure efficient and stable welding.

## 高度防尘

Excellent Dustproof

牢靠的密封性设计, 提高使用寿命  
Reliable sealing design to prolong the lifespan.

## 技术参数 Technical Data

功率等级 Power Rating	12000W
激光波长 Laser Wavelength	1064nm

通光孔径 Clear Aperture	34mm
重量 Weight	~9.0kg

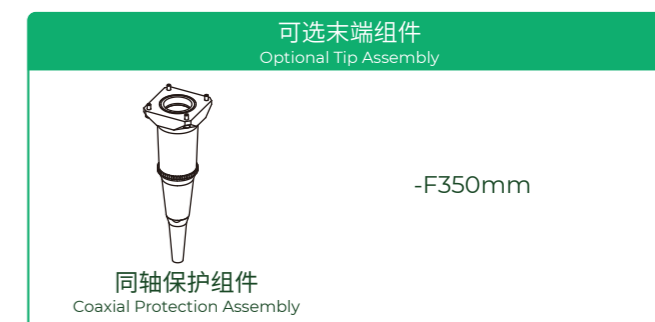
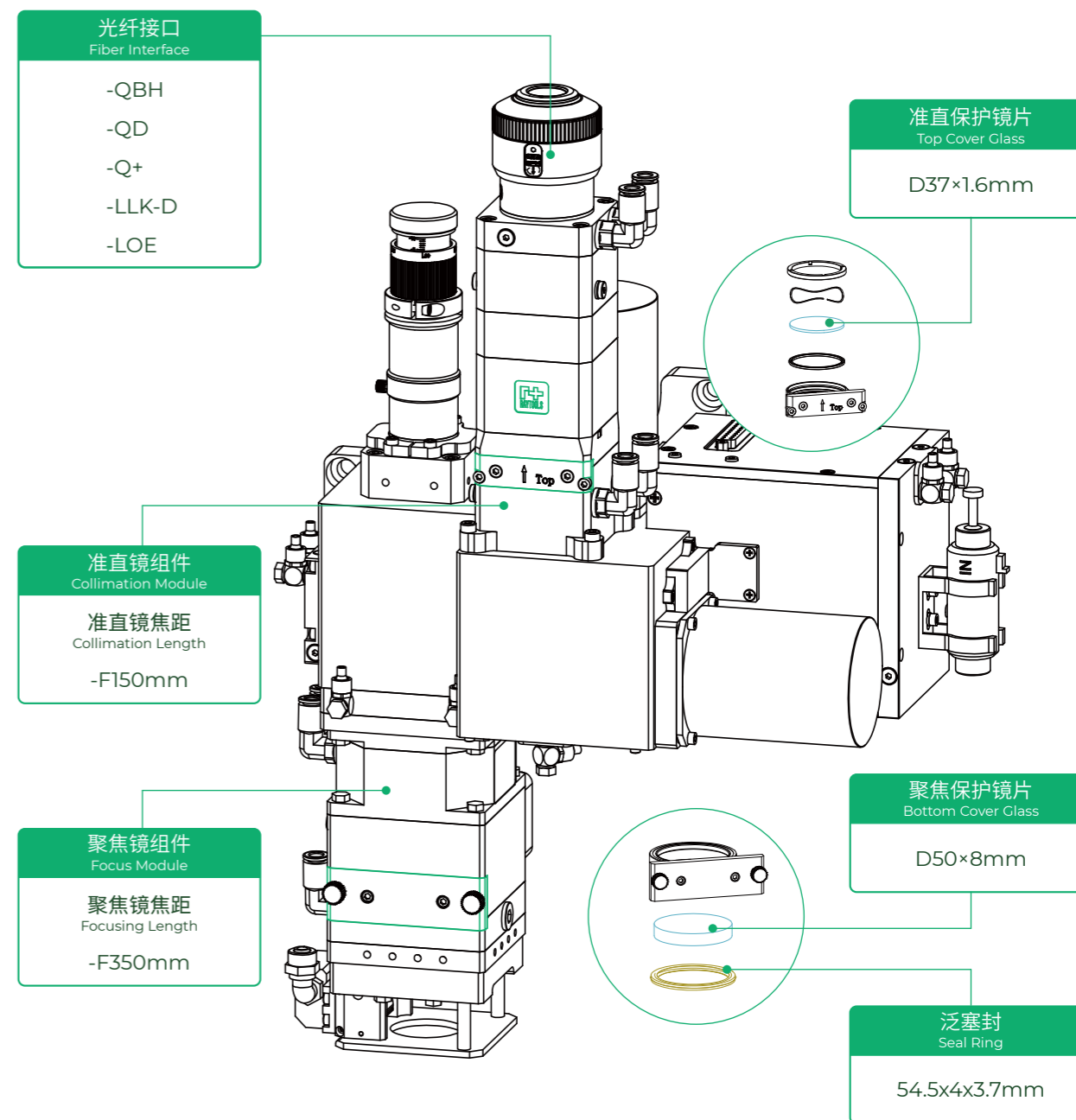



# BG03S

## 振镜焊接头

Galvo Laser Welding Head

功率等级 **3kW**  
Power Rating



更多信息请扫描二维码  
Scan to get details

### 工艺特点

Process Features

焊接速度快, 丰富的扫描图形, 大幅面工作范围  
Fast welding speed, various scanning graphics and large-field working surface.

### 优化设计

Optimized Design

内部密封, 高效防尘, 双保护气刀防渣设计  
Internally sealed and high-efficient for dust-proof, slag-proof design with double-protected air knife.

### 高效水冷

Efficient Water Cooling

整体循环水冷, 运行更稳定可靠。  
Overall circulation of water cooling for more stable and reliable operation.



\*产品图片仅供参考  
\* For Reference Only

### 扩展模块丰富

Rich Function Expanding

CCD监视, 视觉定位, 温控模块  
CCD monitoring, visual positioning, and temperature control module.

### 焊接效果优异

Excellent Welding Effect

优化的光学设计, 高速、高质量的焊道  
Optimized optical design & high-speed and high-quality welding paths.

### 报警反馈

Alarm Feedback

电源欠压, 电机异常报警反馈  
Alarming for power supply undervoltage and abnormal motor activity.

## 技术参数 Technical Data

功率等级 Power Rating	3000W
激光波长 Laser Wavelength	1070±10nm

通光孔径 Clear Aperture	20mm
重量 Weight	~8.5kg

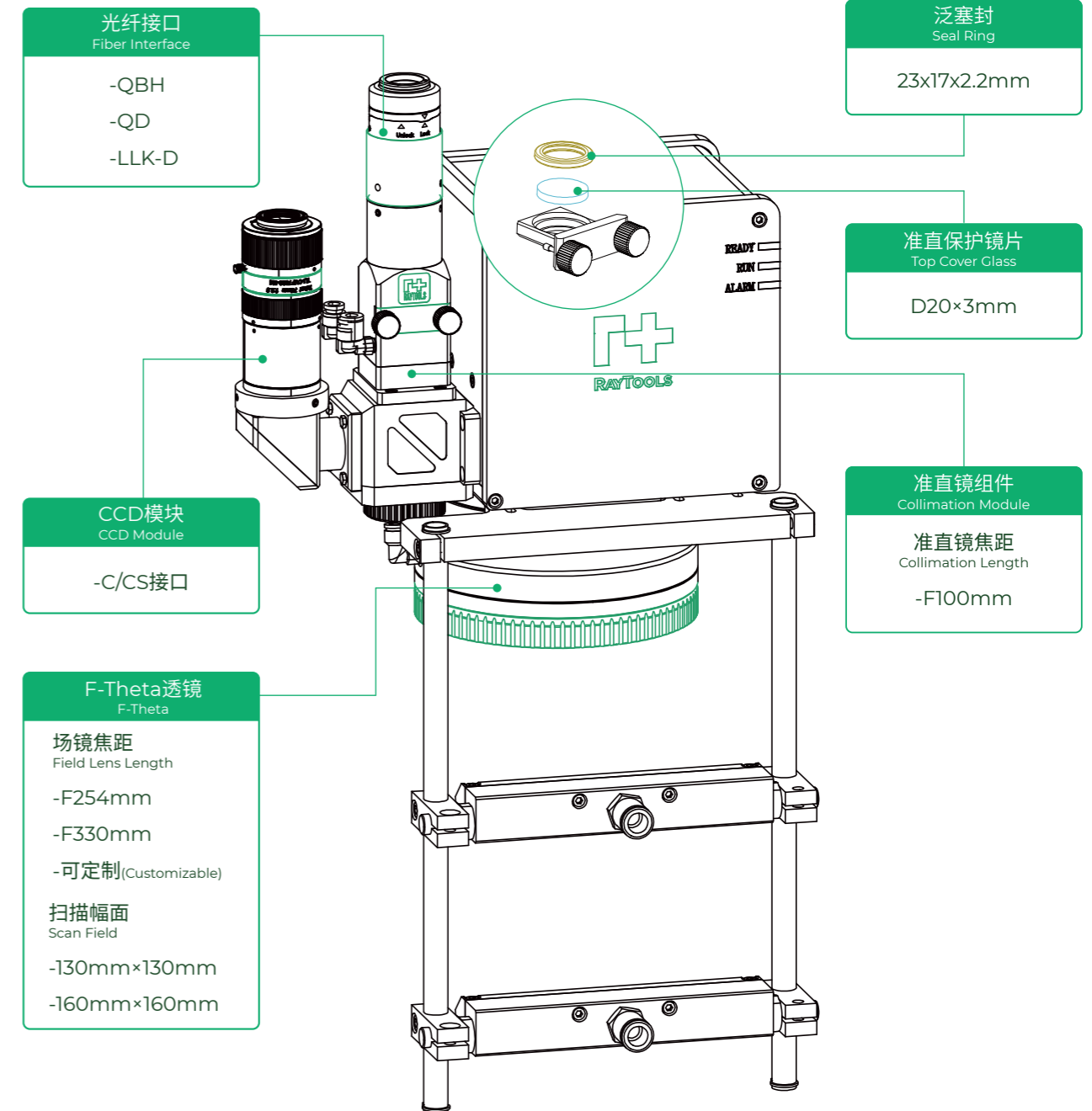

# BG04K

## 振镜焊接头

Galvo Laser Welding Head

功率等级  
Power Rating 4kW



更多信息请扫描二维码  
Scan to get details

### 工艺特点

Process Features

焊接速度快, 丰富的扫描图形,  
大幅面工作范围  
Fast welding speed, various scanning  
graphics and large-field working surface.

### 优化设计

Optimized Design

内部密封, 高效防尘, 双保护气刀  
防渣设计  
Internally sealed and high-efficient for  
dust-proof, slag-proof design with  
double-protected air knife.

### 高效水冷

Efficient Water Cooling

整体循环水冷, 运行更稳定可靠。  
Overall circulation of water cooling for more  
stable and reliable operation.



\*产品图片仅供参考  
\* For Reference Only

### 扩展模块丰富

Rich Function Expanding

CCD监视, 视觉定位, 温控模块  
CCD monitoring, visual positioning, and  
temperature control module.

### 焊接效果优异

Excellent Welding Effect

优化的光学设计, 高速、高质量的焊道  
Optimized optical design & high-speed  
and high-quality welding paths.

### 报警反馈

Alarm Feedback

电源欠压, 电机异常报警反馈  
Alarming for power supply undervoltage  
and abnormal motor activity.

## 技术参数 Technical Data

功率等级 Power Rating	4000W
激光波长 Laser Wavelength	1070±10nm

通光孔径 Clear Aperture	30mm
重量 Weight	~10.0kg

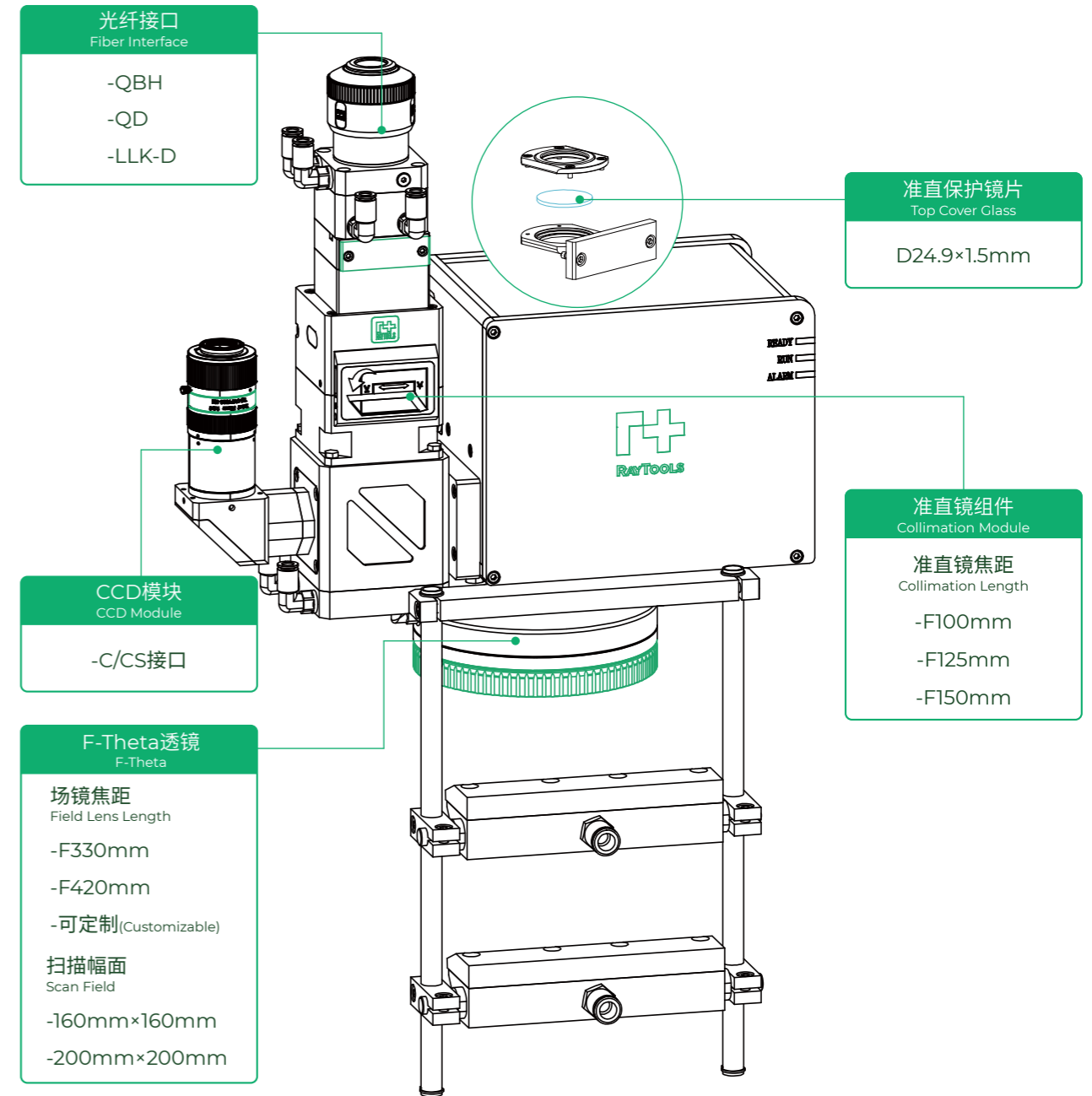

# BF330-6C

振镜焊接头

Galvo Laser Welding Head

功率等级  
Power Rating 6kW



更多信息请扫描二维码  
Scan to get details

## 高功率焊接

High Power Rating

最高能够承受6kW高功率振镜焊接  
The maximum power is up to 6kW to meet the market demand of high power welding.

## 优异的焊接质量

Excellent Welding Quality

低气孔率、高力学性能、高质量焊缝表面  
With low porosity, high mechanical properties and high quality welding surface.

## 丰富的扫描图形

Various Scanning Patterns

可以根据工艺需求在平面内定制任意加工轨迹, 实现大范围加工, F-theta透镜实现聚焦和快速扫描、跳转

The motion path can be customized in a plane for process requirements to achieve large-scale processing. There is a F-theta lens for focusing, quick scanning and transformation.



\*产品图片仅供参考  
\* For Reference Only

## 扩展模块丰富

Rich Function Expanding

可扩展温度传感器、焊缝跟踪或寻位等功能模块, 易于实现自动化焊接  
Modules like temperature sensor, seam tracking and positioning are optional for expanding of function. Make it easy to realize auto welding.

## 高效水冷

Efficient Water Cooling

整体循环水冷, 能够在高功率下长时间稳定地工作  
Integral water cooling circuit to ensure stable and long work at high power.

## 高度防尘

Excellent Dustproof

牢靠的密封性设计, 提高使用寿命  
Reliable sealing design to prolong the lifespan.

## 技术参数 Technical Data

功率等级 Power Rating	6000W
激光波长 Laser Wavelength	1064nm

通光孔径 Clear Aperture	30mm
重量 Weight	~20.0kg

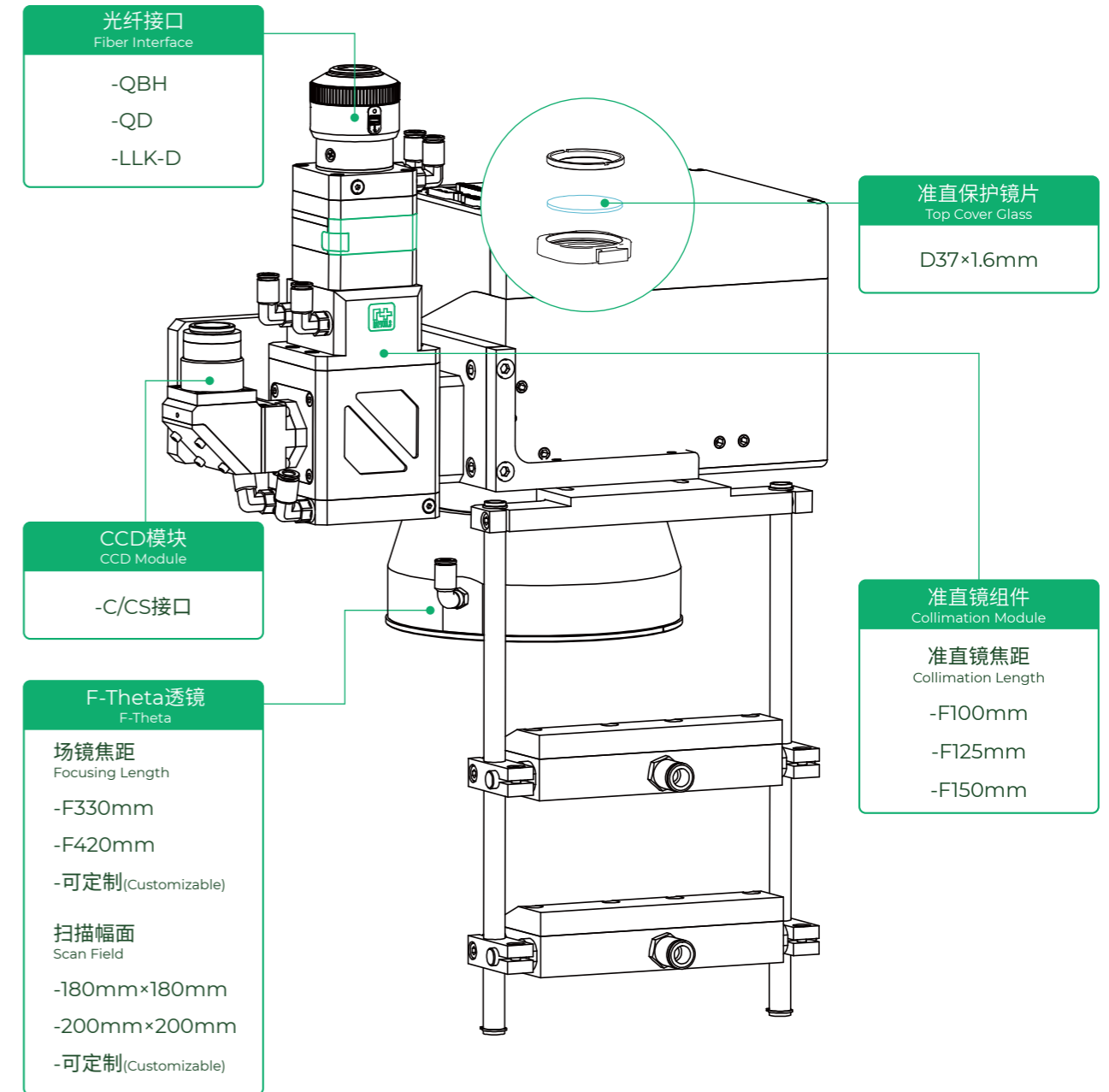

# AK390-BW

高功率多功能激光加工头——焊接

High Power Multifunctional Laser Welding Head

功率等级 **20kW**  
Power Rating

## 高承受功率

High Power Rating

采用直接水冷式铜镜, 镜片使用寿命长, 最高功率可达20kW  
Adapts parabolic copper mirror with direct water cooling to support 20kW high power rating with a long lifespan.

## 高效水冷

Efficient Water Cooling

双水冷结构设计, 保护镜镜座及激光头本体带有水冷接口, 延长持续工作时长  
Double water-cooled structure design, the lens holder and the laser head body are equipped with water-cooled interface to extend the working duration.



\*产品图片仅供参考  
\* For Reference Only



更多信息请扫描二维码  
Scan to get details

## 优异的焊接质量

Excellent Welding Quality

显著提高焊接速度、高表面质量焊接  
Significant improvement of welding speed and high quality welding surface.

## 技术参数 Technical Data

功率等级 Power Rating	20000W
通光孔径 Clear Aperture	48mm

辅助气体气压 Assist Gas Pressure	
- 气刀 Air Knife	6bar
- 焊接保护气 Protective Gas	≤25L/min
重量 Weight	~4.0kg

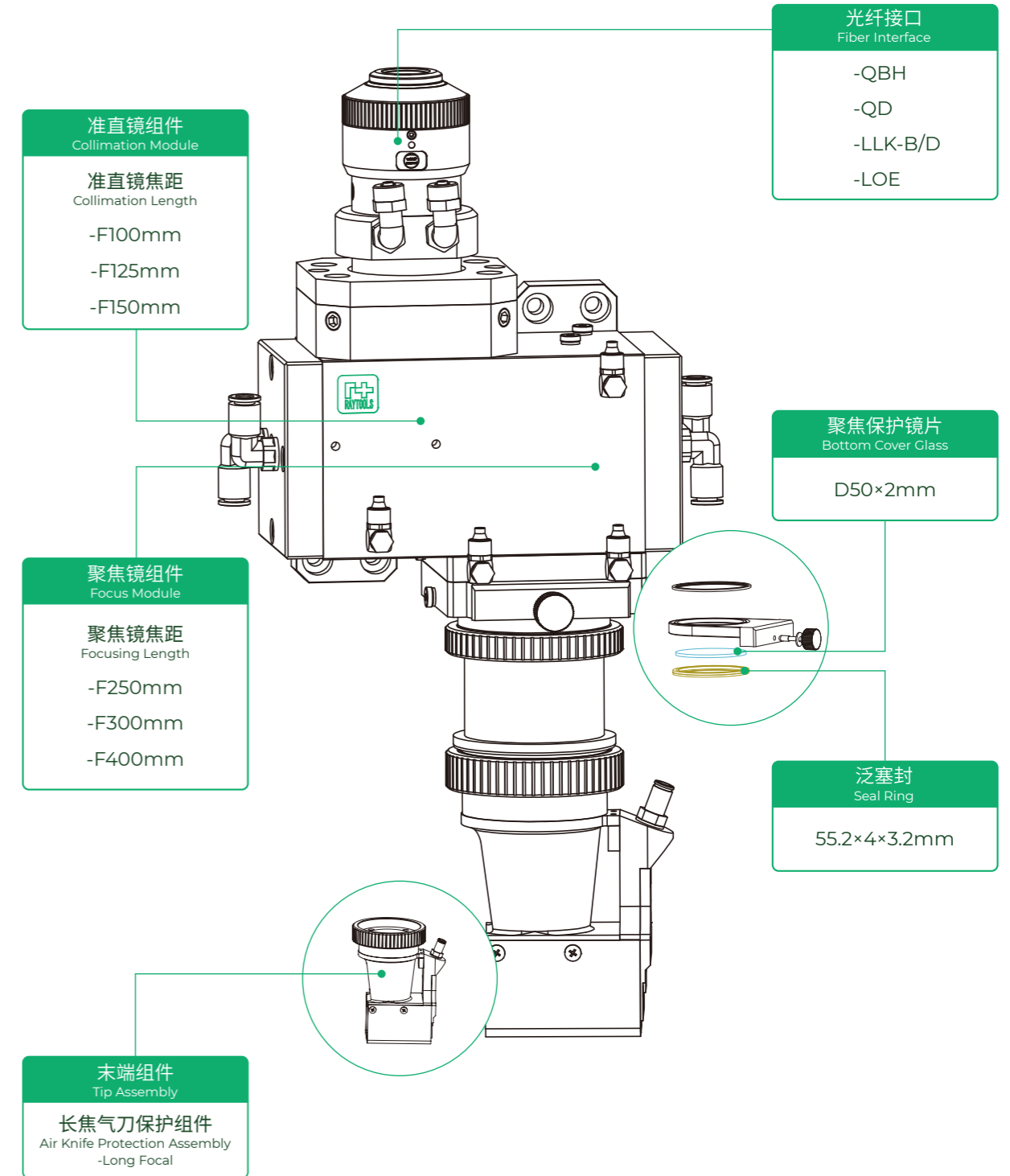



# AK190-TC

反射式激光加工头——熔覆  
Laser Cladding Head - Parabolic Type

功率等级  
Power Rating **6kW**

高承受功率  
High Power Rating

采用直接水冷式铜镜，镜片使用寿命长，最高功率可达6kW  
Adapts parabolic copper mirror with direct water cooling to support 6kW high power rating with a long lifespan.

高效水冷  
Efficient Water Cooling

双水冷结构设计，保护镜镜座及激光头本体带有水冷接口，延长持续工作时长  
Dual water cooling structure with interfaces on both the cover glass holder and the laser head to extend the working duration.



\*产品图片仅供参考  
\* For Reference Only



更多信息请扫描二维码  
Scan to get details

高度兼容  
High Compatibility

具备多种光纤接口，可与各种激光器进行适配  
Various fiber interfaces to work with different prevailing lasers.

焦距定制化  
Focal Length Customization

丰富的准直、聚焦配置，可定制化，满足不同客户需求  
Optional and customizable configurations of collimation lens and focus lens to meet different customer demands.

## 技术参数 Technical Data

功率等级 Power Rating	6000W
辅助气体气压 Assist Gas Pressure	≤5bar
内增压气压 Internal Gas Pressure	≤2bar

通光孔径 Clear Aperture	32mm
重量 Weight	~5.0kg

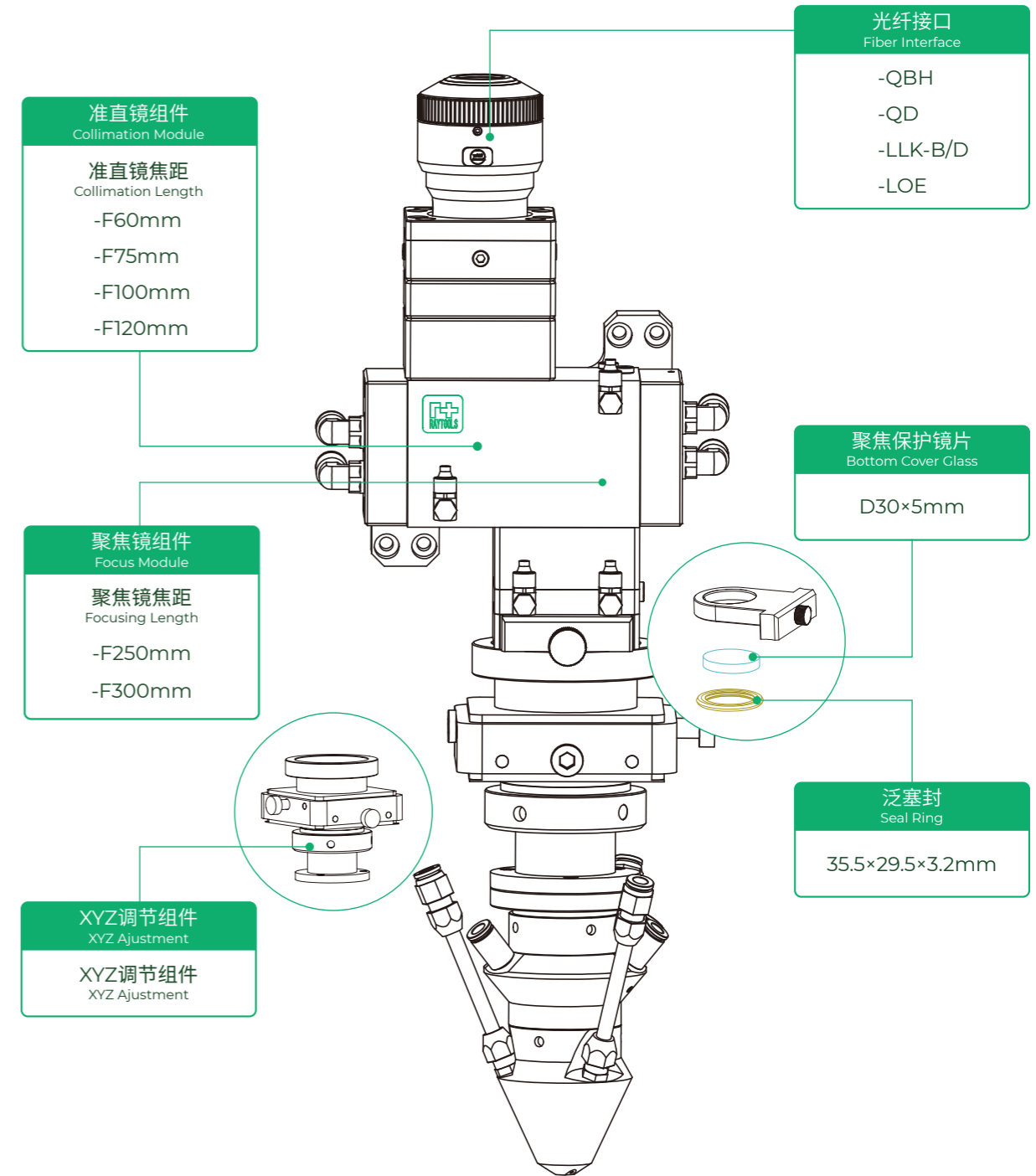

# AK390-TC

高功率多功能激光加工头——熔覆  
High Power Multifunctional Laser Cladding Head

功率等级 20kW  
Power Rating

高承受功率  
High Power Rating

采用直接水冷式铜镜，镜片使用寿命长，最高功率可达20kW  
Adapts parabolic copper mirror with direct water cooling to support 20kW high power rating with a long lifespan.

优化的喷嘴设计  
Optimized Nozzle Design

优化喷嘴设计，具备三路、四路以及环形和宽带喷嘴，满足多样化的加工场景。  
Optimized nozzle design with 3-way, 4-way, ring and broadband nozzles for a variety of processing scenarios.



\*产品图片仅供参考  
\* For Reference Only



更多信息请扫描二维码  
Scan to get details

丰富的送粉形式

Various Powder Feeding Methods

配置不同末端组件可实现高功率的激光  
三路送粉熔覆、环形送粉熔覆等功能  
Equipped with different tip assemblies for corresponding functions like 3-way powder feeding cladding and annular powder feeding cladding, etc.

高效水冷

Efficient Water Cooling

双水冷结构设计，保护镜镜座及激光头  
本体带有水冷接口，延长持续工作时长  
Dual water cooling structure with interfaces on both the cover glass holder and the laser head to extend the working duration.

## 技术参数 Technical Data

功率等级 Power Rating	20000W
辅助气体气压 Assist Gas Pressure	2-3bar

通光孔径 Clear Aperture	48mm
重量 Weight	~7.5kg

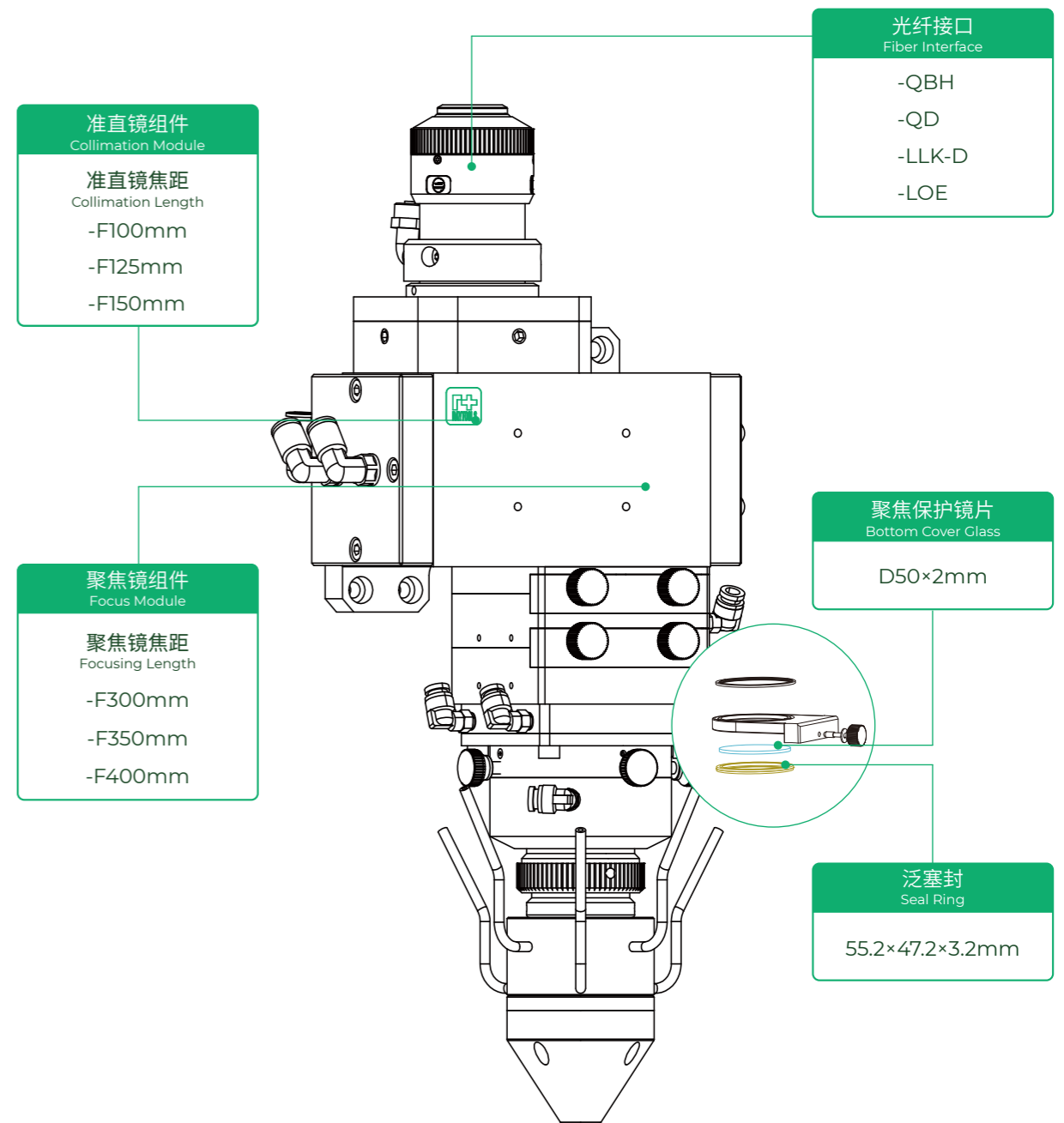

# AK390-PC

高功率多功能激光加工头——宽带熔覆

High Power Multifunctional Wideband Laser Cladding Head

功率等级 **20kW**  
Power Rating

高承受功率  
High Power Rating

采用直接水冷式铜镜，镜片使用寿命长，最高功率可达20kW  
Adapts parabolic copper mirror with direct water cooling to support 20kW high power rating with a long lifespan.



\*产品图片仅供参考  
\* For Reference Only

## 技术参数 Technical Data

功率等级 Power Rating	20000W
通光孔径 Clear Aperture	48mm
辅助气体气压 Assist Gas Pressure	≤5bar
角度调节范围 Angle Range	3°*10
重量 Weight	~7.0kg

积分镜光斑尺寸 KIS Spot Size	10×2mm 15×2mm 20×2mm 20×4mm 可定制
轴微调范围 Axis Range	- X 方向 ±15mm - Y 方向 ±15mm - Z 方向 ±30mm



更多信息请扫描二维码  
Scan to get details

### 熔覆效率高

High Deposition Efficiency

送粉喷嘴由两路气体保护，通过重力送粉，粉末利用率可达90%，实现高效率激光熔覆  
The powder injection nozzle is protected by two way air protection, and the powder can be used up to 90% by gravity, which can achieve the high efficiency laser cladding.

### 高效水冷

Efficient Water Cooling

双水冷结构设计，保护镜镜座及激光头本体带有水冷接口，延长持续工作时长  
Dual water cooling structure with interfaces on both the cover glass holder and the laser head to extend the working duration.

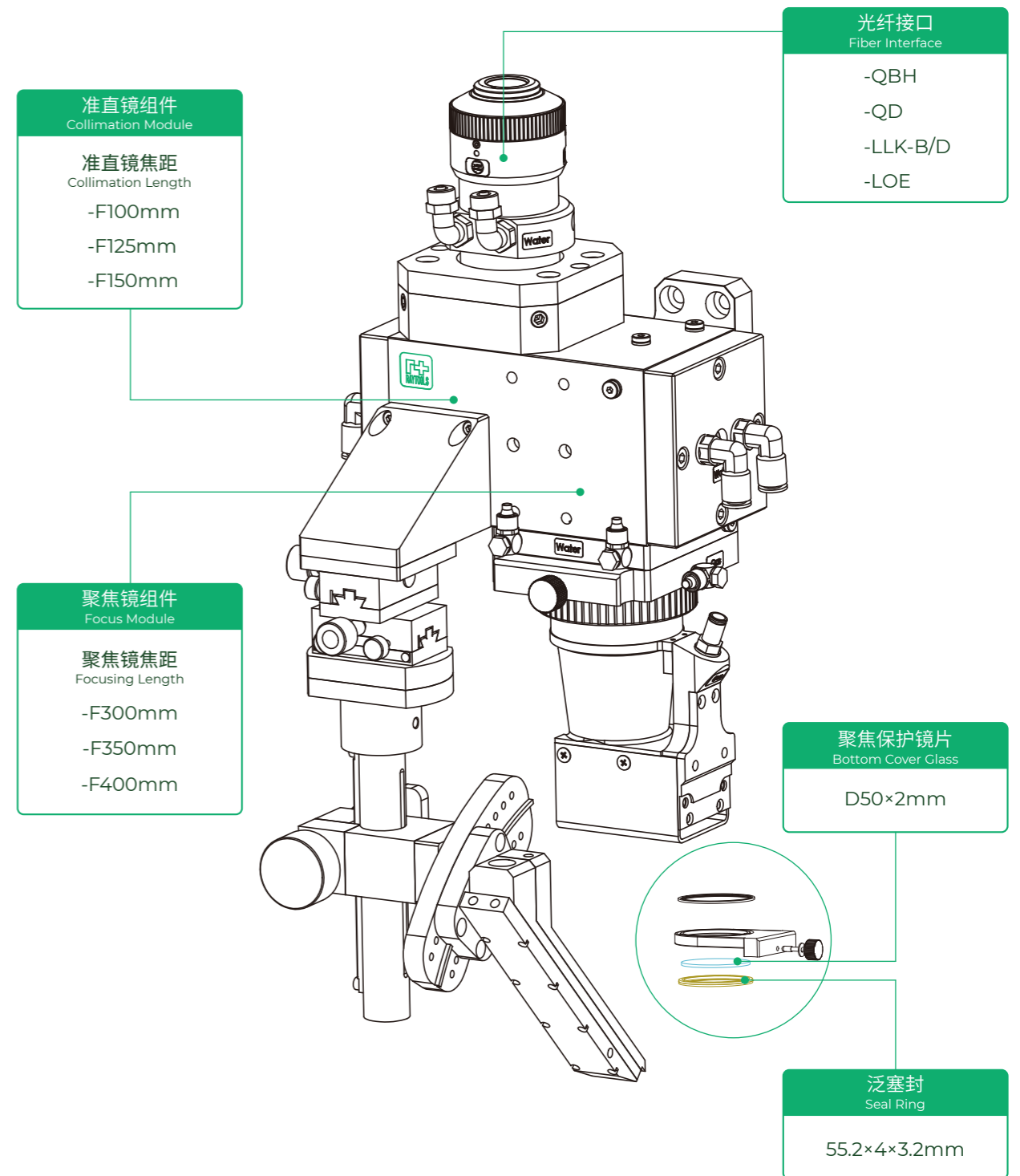

# BC104

## 透射式激光熔覆头

Laser Cladding Head - Transmission Type

功率等级 **4kW**  
Power Rating



更多信息请扫描二维码  
Scan to get details

### 高效冷却

Efficient Cooling

所有镜片均有水路冷却且水路独立于整头外部, 没有内部漏水风险  
All lenses are water-cooling and the cooling system is independent from the laser head, with no risk of internal water leakage.

### 准直可调

Adjustable Collimation

通过调节准直镜片位置改变加工位置光斑尺寸  
Change the spot size of the processing position by adjusting the position of the collimation lens.

### 相机监测

Camera Monitoring

配置CCD相机进行加工过程监测  
Configure CCD camera for process monitoring.



\*产品图片仅供参考  
\* For Reference Only

### 封闭式设计

Enclosed Design

全封闭防尘设计, 避免光学部分受到灰尘污染  
Fully enclosed dust-proof design to avoid dust contamination of the optical part.

### 多功能设计

Multifunctional Design

可以适配三路、四路、环形、高速熔覆等喷嘴, 满足多场景应用  
Meet various requirements with different nozzles. Three-way, four-way, annular, high-speed cladding nozzle and other types are all available.

### 模块化设计

Modular Design

可以选配CCD成像、温度监控以及保护镜片温度监测等功能  
Optional CCD imaging, temperature monitoring and cover glass temperature monitoring and other functions.

## 技术参数 Technical Data

功率等级 Power Rating	4000W
透射波长 Transmission Wavelength	1060-1080nm
适用光源 Applicable Light Source	光纤激光器 Fiber Laser
粉末汇聚尺寸 Powder Aggregate Size	1-3mm可选 1-3mm Optional
工作高度 Working Distance	13-16mm

喷嘴 Nozzle	三路、四路、环形、高速可选 Optional 3-way, 4-way, Annular, High-speed Cladding Nozzle
选配 Optional	CCD组件 CCD Module 红光定位组件 Red-light Locator Module 保护镜片温度监测单元 Cover Glass Temperature Monitoring 分粉器 Powder Splitter 闭环温控单元等 Closed-loop Temperature Control Module, etc
重量 Weight	~5.0kg

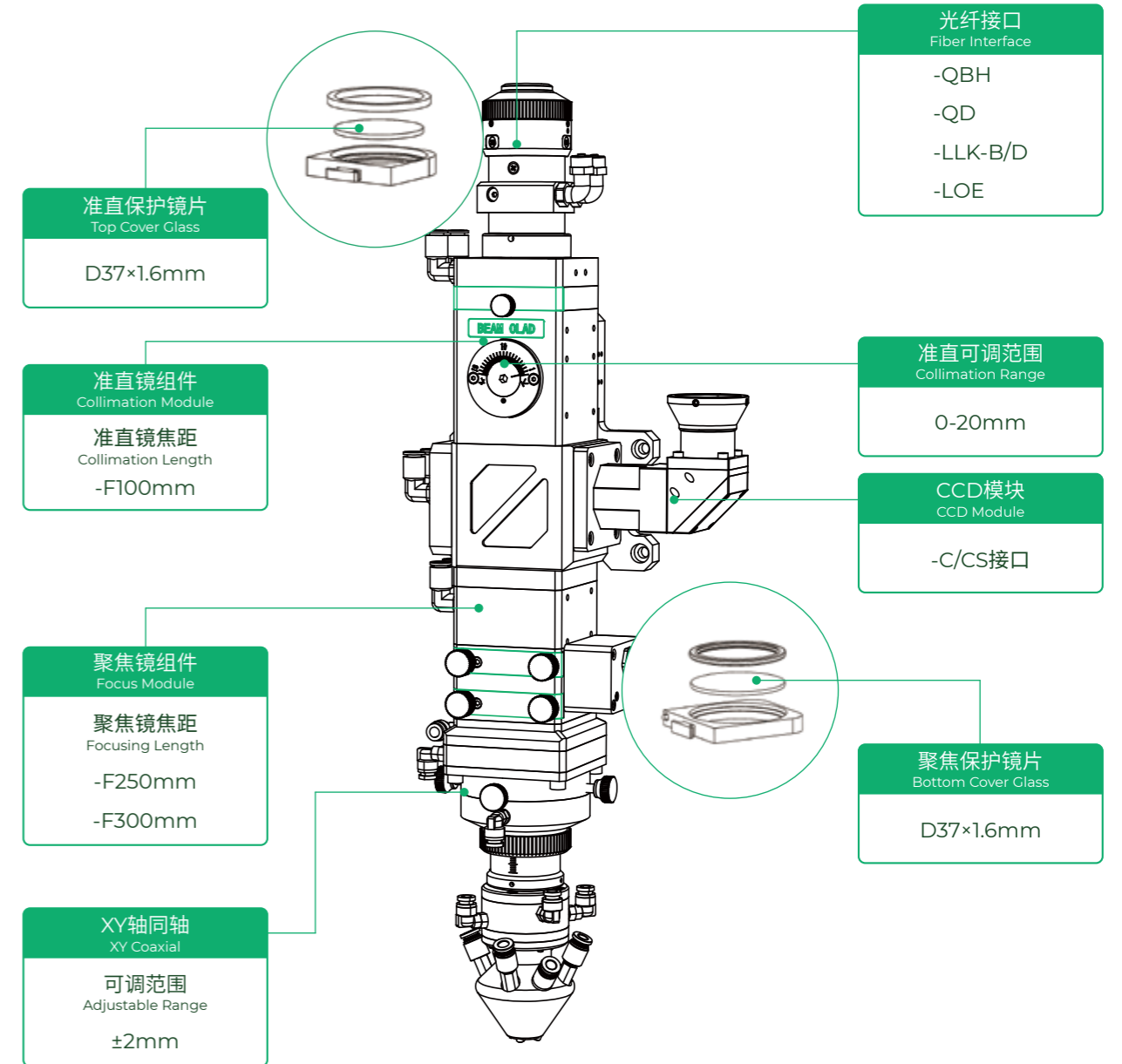



# BC106

## 透射式高功率激光熔覆头

High Power Laser Cladding Head - Transmission Type

功率等级  
Power Rating

6kW 更多信息请扫描二维码  
Scan to get details



### 高承受功率

High Power Rating

搭配D50光学镜组, 承受功率6kW  
With D50 optical lens group, maximum power is up to 6kW.

### 高效冷却

Efficient Water Cooling

所有镜片均有水路冷却且水路独立于整头外部, 没有内部漏水风险  
All lenses are water-cooling, and the cooling system is independent from the laser head, without risk of internal water leakage.

### 相机监测

Camera Monitoring

配置CCD相机进行加工过程监测  
Configure CCD camera for process monitoring.



\*产品图片仅供参考  
\* For Reference Only

### 封闭式设计

Enclosed Design

全封闭防尘设计, 避免光学部分受到灰尘污染  
Fully enclosed dust-proof design to avoid dust contamination of the optical part.

### 准直调焦

Collimation Focusing

准直调焦, 焦点可调范围相比传统聚焦调焦范围更大  
The focusing range adjusted by the collimation is larger than the traditional focusing range.

### 大通光孔径

Large Clear Aperture

整头通光孔径48mm, 有效降低杂散光干扰, 保障熔覆质量及使用寿命  
The clear aperture of the laser head is 48mm, which can effectively reduce the interference of stray light and ensure the cladding effect.

## 技术参数 Technical Data

功率等级 Power Rating	6000W
透射波长 Transmission Wavelength	900-1100nm
适用光源 Applicable Light Source	光纤激光器, 半导体激光器 Fiber Laser, Diode Laser
粉末汇聚尺寸 Powder Aggregate Size	1-3mm可选 1-3mm Optional
工作高度 Working Distance	13-16mm

喷嘴 Nozzle	三路、四路、环形、高速可选 Optional 3-way, 4-way, Annular, High-speed Cladding Nozzle
选配 Optional	CCD组件 CCD Module 红光定位组件 Red-light Locator Module 保护镜片温度监测单元 Cover Glass Temperature Monitoring 分粉器 Powder Splitter 闭环温控单元等 Closed-loop Temperature Control Module, etc
重量 Weight	~7.0kg

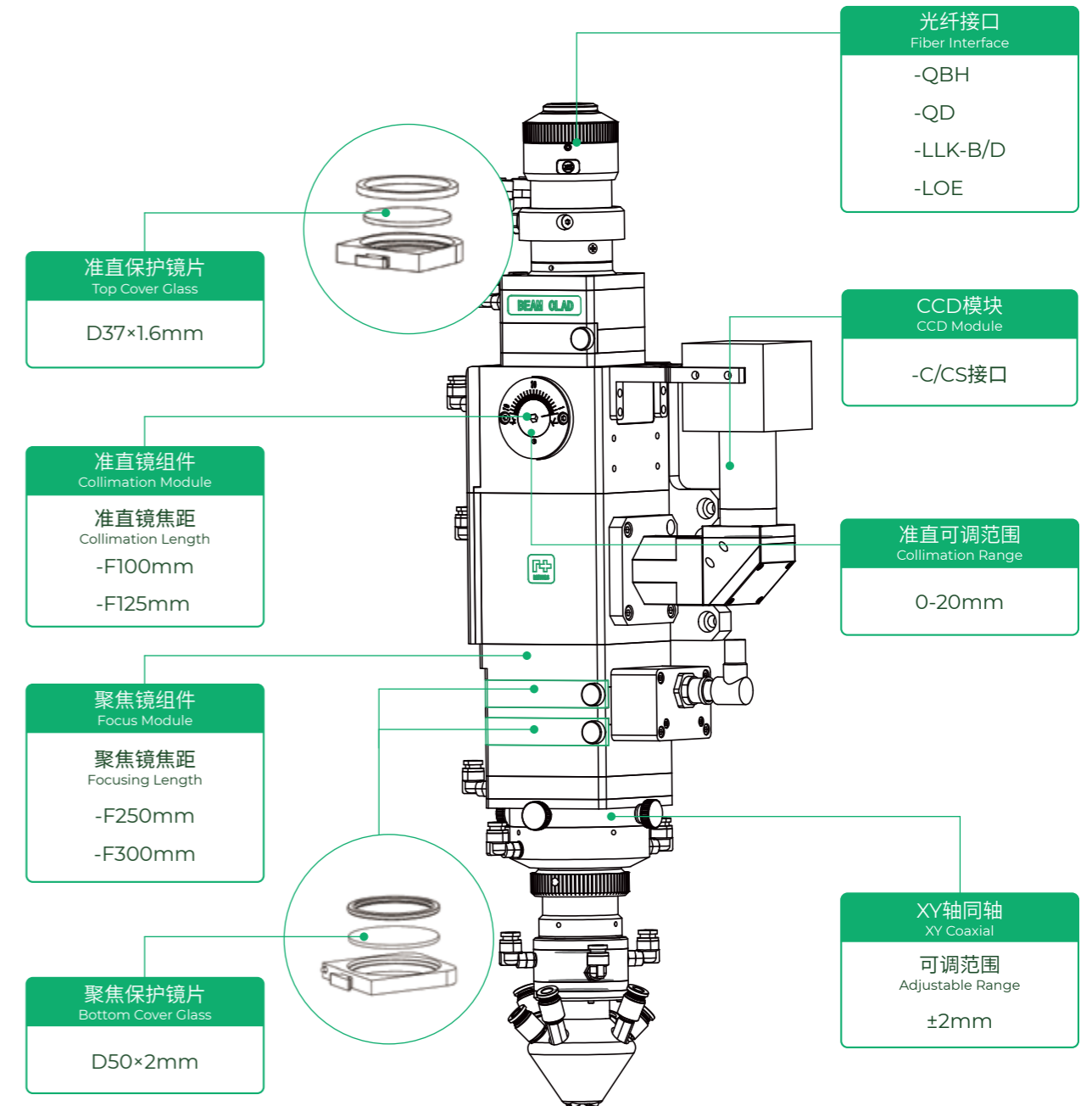

# VB106

## 多功能激光加工头

Multifunctional Laser Processing Head

功率等级 **6kW**  
Power Rating



更多信息请扫描二维码  
Scan to get details

### 高效冷却

Efficient Cooling

所有镜片均有水路冷却且水路独立于整头外部, 没有内部漏水风险

All lenses are water-cooling, and the cooling system is independent from the laser head, without risk of internal water leakage.

### 准直可调

Focus Adjustable

调节准直镜片位置可以改变焦点位置光斑尺寸, 适应不同光斑加工需求

Manually adjusting the position of the collimating lens with a hex key to change the size of the focal spot for different processing needs.

### 多功能设计

Multifunctional Design

可以通过手动/电动方式实现圆形-矩形光斑的自动切换, 适配对应的同轴保护模块、送粉喷嘴和横吹保护单元来满足激光焊接、熔覆和淬火多功能加工需求

The automatic switching between circular and rectangular spots can be realized by manual/electrical mode, which can fit the corresponding coaxial assembly, powder feeding nozzle and side blow assembly. Meet the multifunctional processing requirements of laser welding, cladding and hardening.



\*产品图片仅供参考  
\*For Reference Only

### 相机监测

Camera Monitoring

配置CCD相机可以进行激光加工位置的快速定位及加工过程监测  
Equipped CCD camera can quickly locate the processing position and monitor the process.

### 封闭式设计

Enclosed Design

全封闭防尘设计, 避免光学部分受到灰尘污染

Fully enclosed dust-proof design to avoid dust contamination of the optical part.

### 模块化设计

Modular Design

可以适配闭环温控单元、保护镜片温度监测、三路/四路/环形/宽带熔覆喷嘴等

Optional modules includes closed-loop temperature control, cover glass temperature monitoring, three-way/four-way/annular/wide-band cladding nozzle, etc.

## 技术参数 Technical Data

功率等级 Power Rating	6000W
透射波长 Transmission Wavelength	900-1100nm
适用光源 Applicable Light Source	光纤激光器, 半导体激光器 Fiber laser, Diode laser
激光入射方向 Laser Incident Direction	0°/90°
焦点光斑形状 Focus Spot Shape	圆形、矩形自主切换 Circular/Rectangular Automatic Switching
矩形光斑尺寸 Rectangular Spot Size	10×3mm, 15×3mm, 20×3mm, 30×3mm等

粉末汇聚尺寸 Powder Aggregate Size	1-3mm可选 1-3mm Optional
工作高度 Working Distance	13-16mm
快换单元 Quick Change Unit	三路/四路/环形熔覆喷嘴, 同轴保护单元, 侧吹单元 3-way/4-way/Annular Cladding Nozzle, Coaxial Assembly and Side-blow Assembly
选配 Optional	CCD组件 CCD Module 红光定位组件 Red-light Locator Module 保护镜片温度监测单元 Cover Glass Temperature Monitoring 分粉器 Powder Splitter 闭环温控单元等 Closed-loop Temperature Control Module, etc
重量 Weight	~7.0kg

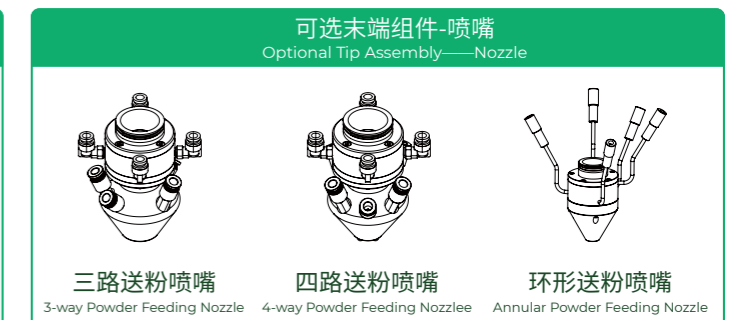
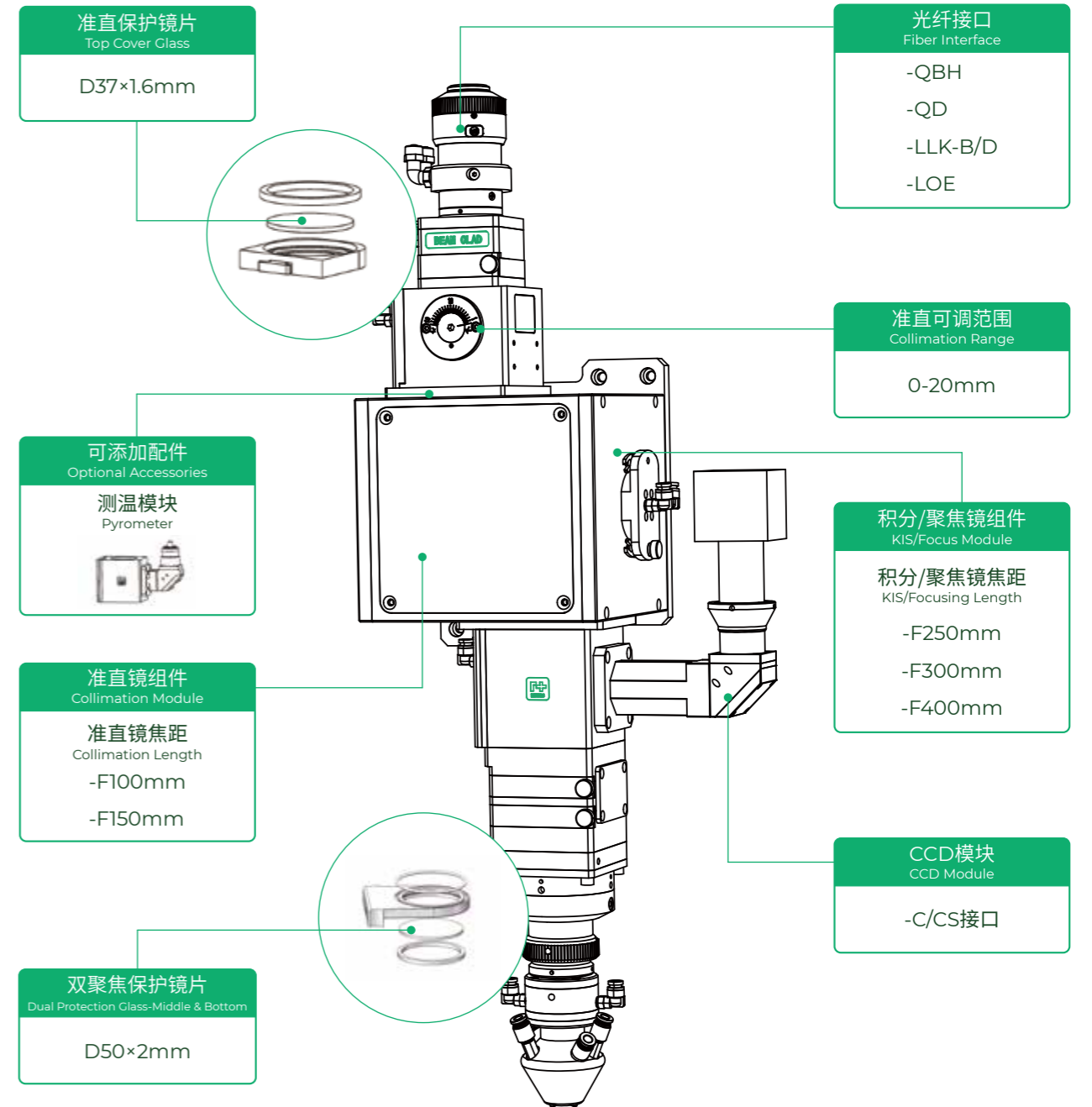

# IC104

内孔激光熔覆头  
Inner Tube Laser Cladding Head

功率等级 **4kW**  
Power Rating



更多信息请扫描二维码  
Scan to get details



\*产品图片仅供参考  
\* For Reference Only

## 高效冷却 Efficient Cooling

所有水路、光路、气路以及粉路集成在熔覆头内部，冷却性能优异  
All the water, light, gas and powder circuits are integrated inside the cladding head with excellent cooling performance.

## 封闭式设计 Enclosed Design

全封闭防尘设计，避免光学部分受到灰尘污染  
Fully enclosed dust-proof design to avoid dust contamination of the optical part.

## 技术参数 Technical Data

功率等级 Power Rating	4000W
透射波长 Transmission Wavelength	1060-1080nm
适用光源 Applicable Light Source	光纤激光器 Fiber Laser
粉末汇聚尺寸 Powder Aggregate Size	1-3mm可选
调焦范围 Focusing Range	0-20mm

最小加工孔径 Min Machining Aperture	100mm
最大加工深度 Max Machining Depth	1.5m (单侧) Single Side
推荐激光器芯径 Max Machining Depth	200μm
选配 Optional	分粉器 Powder Splitter

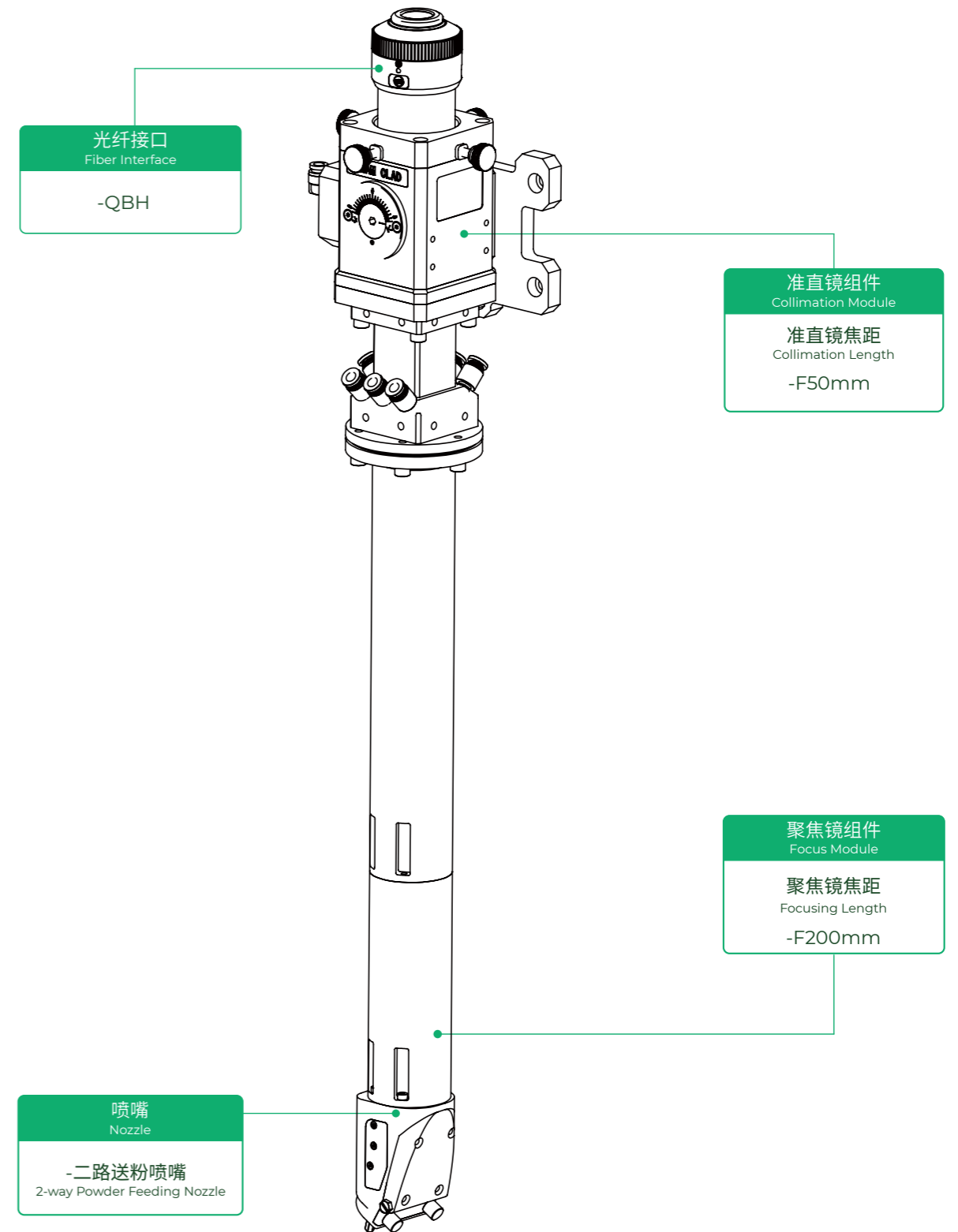

# AK090-HT

激光淬火头  
Laser Hardening Head

功率等级 3kW  
Power Rating



更多信息请扫描二维码  
Scan to get details

高承受功率  
High Power Rating

单铜镜直接水冷, 镜片使用寿命长, 最高功率可达3kW  
Adapts single piece parabolic copper mirror with direct water cooling to support 3kW high power rating with a long lifespan.



\*产品图片仅供参考  
\* For Reference Only

体积小巧  
Compact and Agile

较小的体积, 方便实现狭小位置焊接  
Compact size with easy access to narrow space.

重量轻便  
Light-duty

降低机床负载, 完成高速加工  
Light-duty to reduce the payload of machine tool and fulfill high speed processing.

高效水冷  
Efficient Water Cooling

双水冷结构设计, 保护镜座及激光头  
本体带有水冷接口  
Dual water cooling structure with interfaces on both the cover glass holder and the laser head to extend the working duration.

## 技术参数 Technical Data

功率等级 Power Rating	3000W
通光孔径 Clear Aperture	32mm

辅助气体气压 Assist Gas Pressure	
- 气刀 Air Knife	8bar
- 焊接保护气 Protective Gas	≤25L/min
重量 Weight	~2.0kg

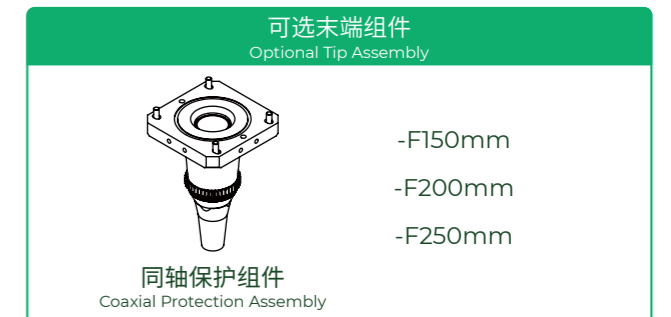
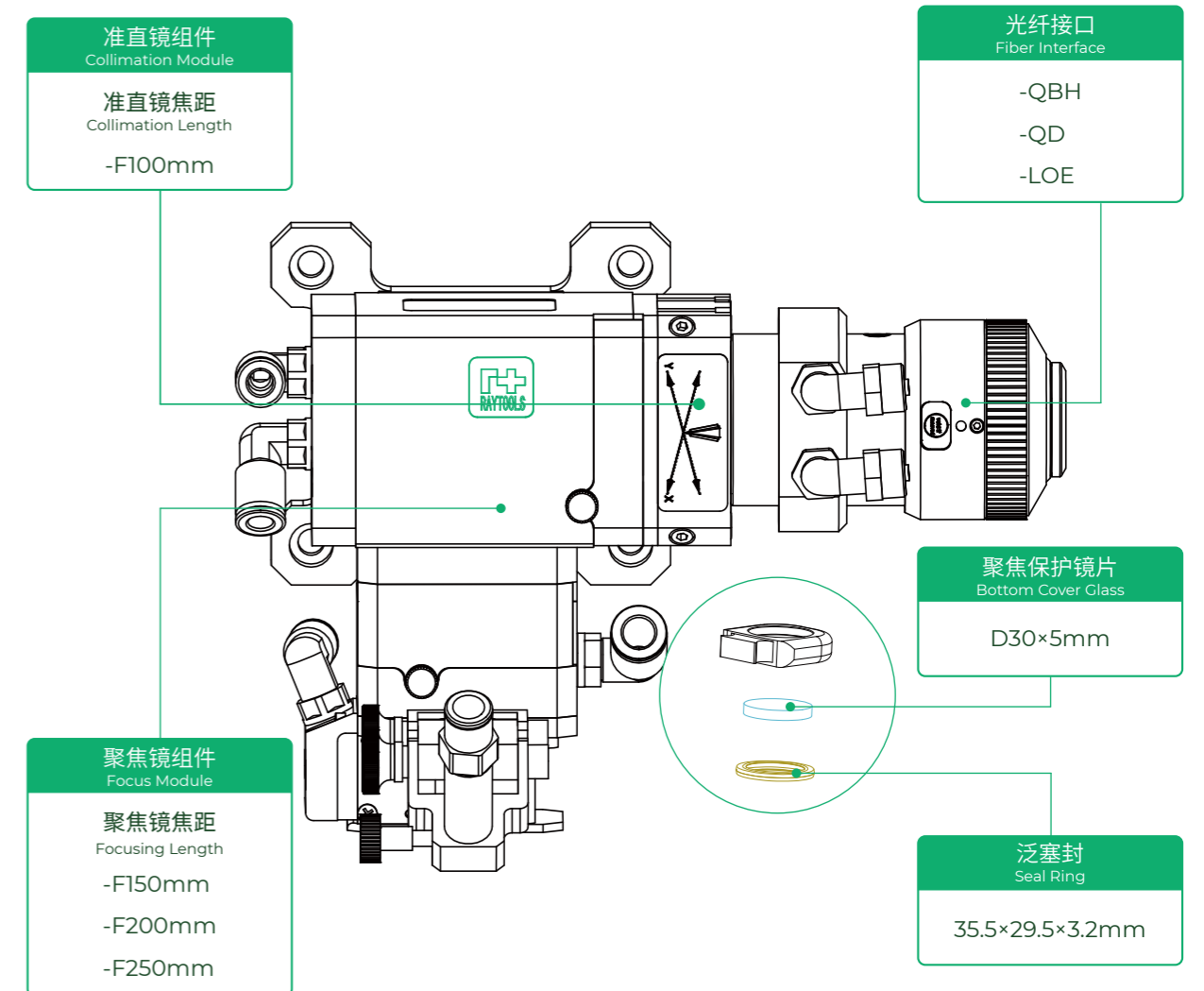



# AK190-HT

多功能激光加工头——淬火  
Multifunctional Laser Hardening Head

功率等级 **3kW**  
Power Rating

高承受功率  
High Power Rating

采用直接水冷式铜镜，镜片使用寿命长，最高功率可达3kW  
Adapts parabolic copper mirror with direct water cooling to support 3kW high power rating with a long lifespan.

积分镜片可定制  
KIS can be Customized

根据需求可定制不同尺寸的积分镜，实现不同尺寸光斑的表面淬火功能

Integrating mirrors of different sizes can be customized according to the requirements to achieve the surface hardening function of different sizes of light spots.



\*产品图片仅供参考  
\* For Reference Only



更多信息请扫描二维码  
Scan to get details

## 高效水冷

Efficient Water Cooling

双水冷结构设计，保护镜镜座及激光头本体带有水冷接口，延长持续工作时长

Dual water cooling structure with interfaces on both the cover glass holder and the laser head to extend the working duration.

## 技术参数 Technical Data

功率等级 Power Rating	3000W	10×2mm
通光孔径 Clear Aperture	32mm	15×2mm
辅助气体气压 Assist Gas Pressure	≤6bar	20×2mm
重量 Weight	~4.0kg	20×4mm
		可定制

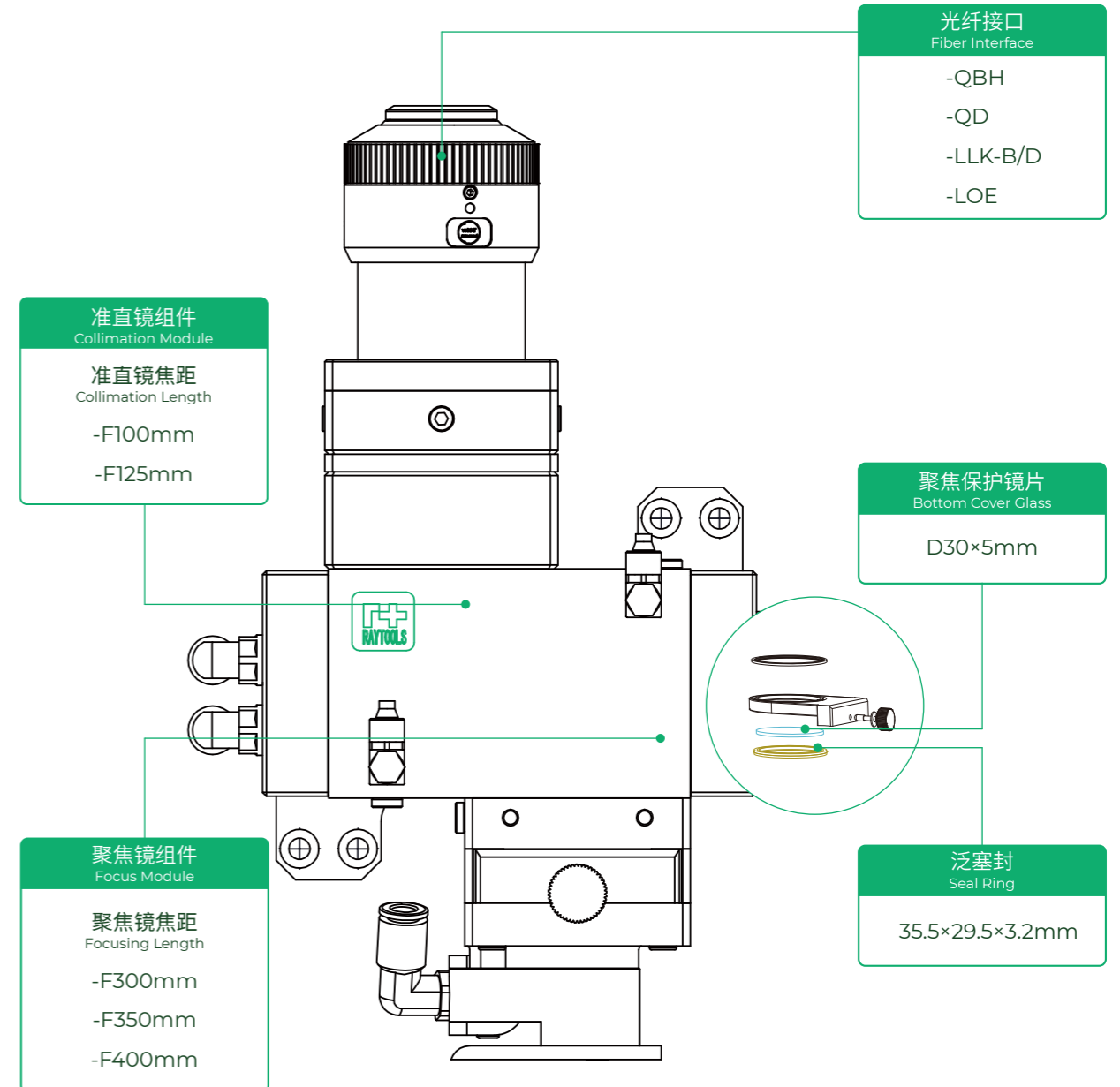

# AK390-HT

高功率多功能激光加工头——淬火  
High Power Multifunctional Laser Hardening Head

功率等级 6kW-20kW  
Power Rating

高承受功率  
High Power Rating

采用直接水冷式铜镜，镜片使用寿命长，最高功率可达20kW  
Adapts parabolic copper mirror with direct water cooling to support 20kW high power rating with a long lifespan.

积分镜片可定制  
KIS can be Customized

根据需求可定制不同尺寸的积分镜，实现不同尺寸光斑的表面淬火功能

Integrating mirrors of different sizes can be customized according to the requirements to achieve the surface hardening function of different sizes of light spots.



\*产品图片仅供参考  
\* For Reference Only



更多信息请扫描二维码  
Scan to get details

## 高效水冷

Efficient Water Cooling

双水冷结构设计，保护镜镜座及激光头本体带有水冷接口，延长持续工作时长

Dual water cooling structure with interfaces on both the cover glass holder and the laser head to extend the working duration.

## 技术参数 Technical Data

功率等级 Power Rating	6000W-20000W
通光孔径 Clear Aperture	48mm
辅助气体气压 Assist Gas Pressure	≤6bar
重量 Weight	~6.0kg

	10×2mm
	15×2mm
积分镜光斑尺寸 KIS Spot Size	20×2mm
	20×4mm
	可定制

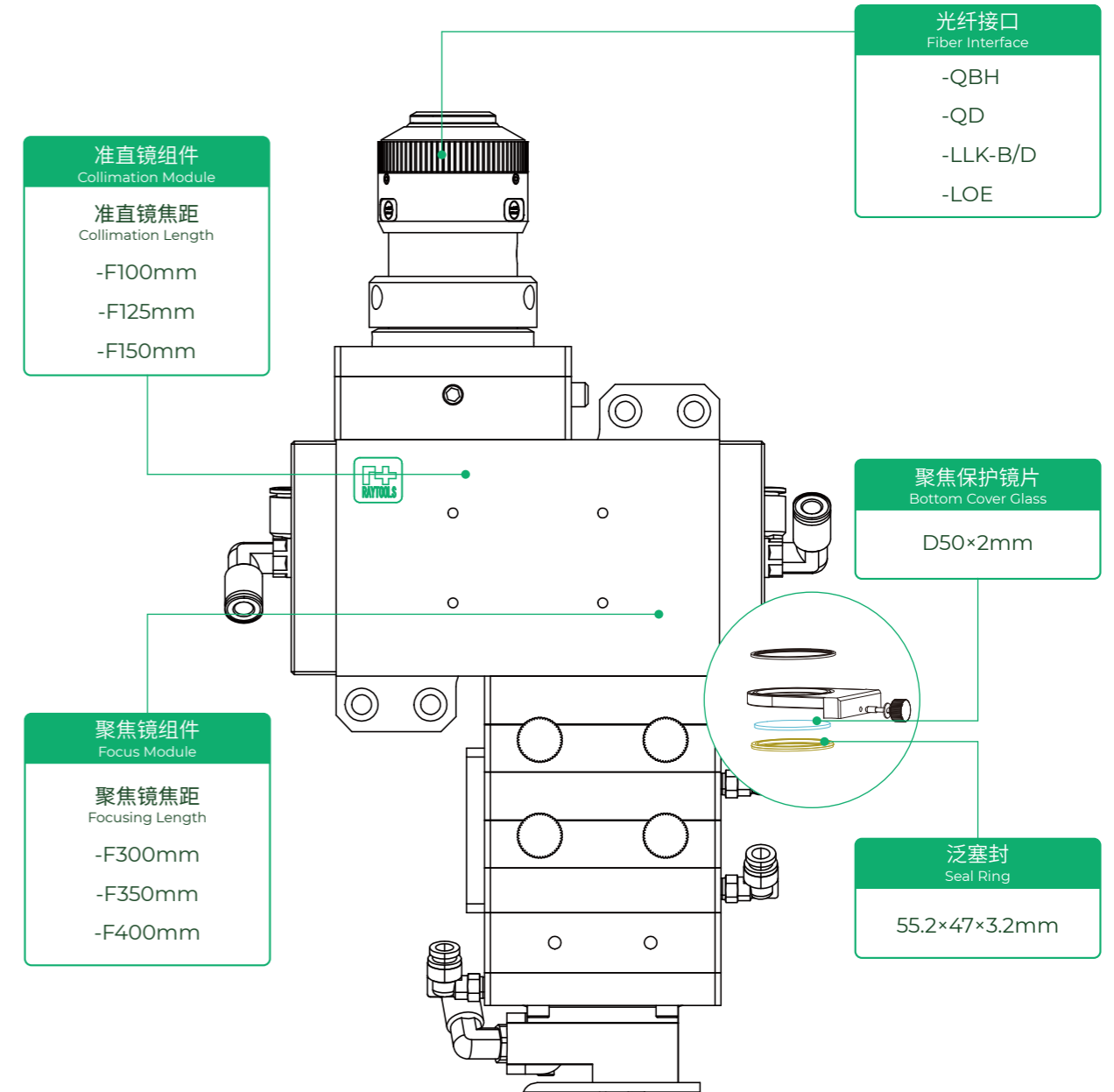

# BF340-3F

单振镜封边焊接头  
Single Galvo Laser Banding Head

功率等级 3kW  
Power Rating



更多信息请扫描二维码  
Scan to get details

## 单振镜激光封边头

Single Galvo Laser Banding Head

专为激光封边场景设计, 60mm摆动幅度  
适配各种板厚, 工艺参数调试方便, 参数存  
储一键切换

Specially designed for laser band sealing, with  
60mm wobble size for sheets with different  
thicknesses, easy debugging of process.



\*产品图片仅供参考  
\* For Reference Only

## 优化结构设计

Optimized Structural Design

体积小不易干涉, 安装简单, 易于  
改造线装配

Small size with less interference and simple  
installation, easy to retrofit line assembly.

## 专用激光封边控制系统

Dedicated Laser Banding Control System

工艺参数一键切换, 激光控制准确稳定,  
支持外部通讯控制, 实现工业一体化

Quick switching for process parameters, accurate  
and stable laser control, supporting for external  
communication control to industrial integration.

## 优化光学设计

Optimized Optical Design

采用4mm大光斑光学方案, 封边带辐射  
更均匀, 工艺调试不易起火, 即使带胶涂  
布不均匀, 也能实现稳定加工

4mm large-spot optical solution, with more  
uniform sealing tape laser. Burning in debugging is  
less possible, therefore, stable processing can be  
achieved even if the tape is unevenly coated.

## 技术参数 Technical Data

功率等级 Power Rating	3000W
激光波长 Laser Wavelength	1064nm
摆动幅度 Wobble Amplitude	0-60mm

摆动频率 Wobble Frequency	0-500Hz
重量 Weight	~1.8kg

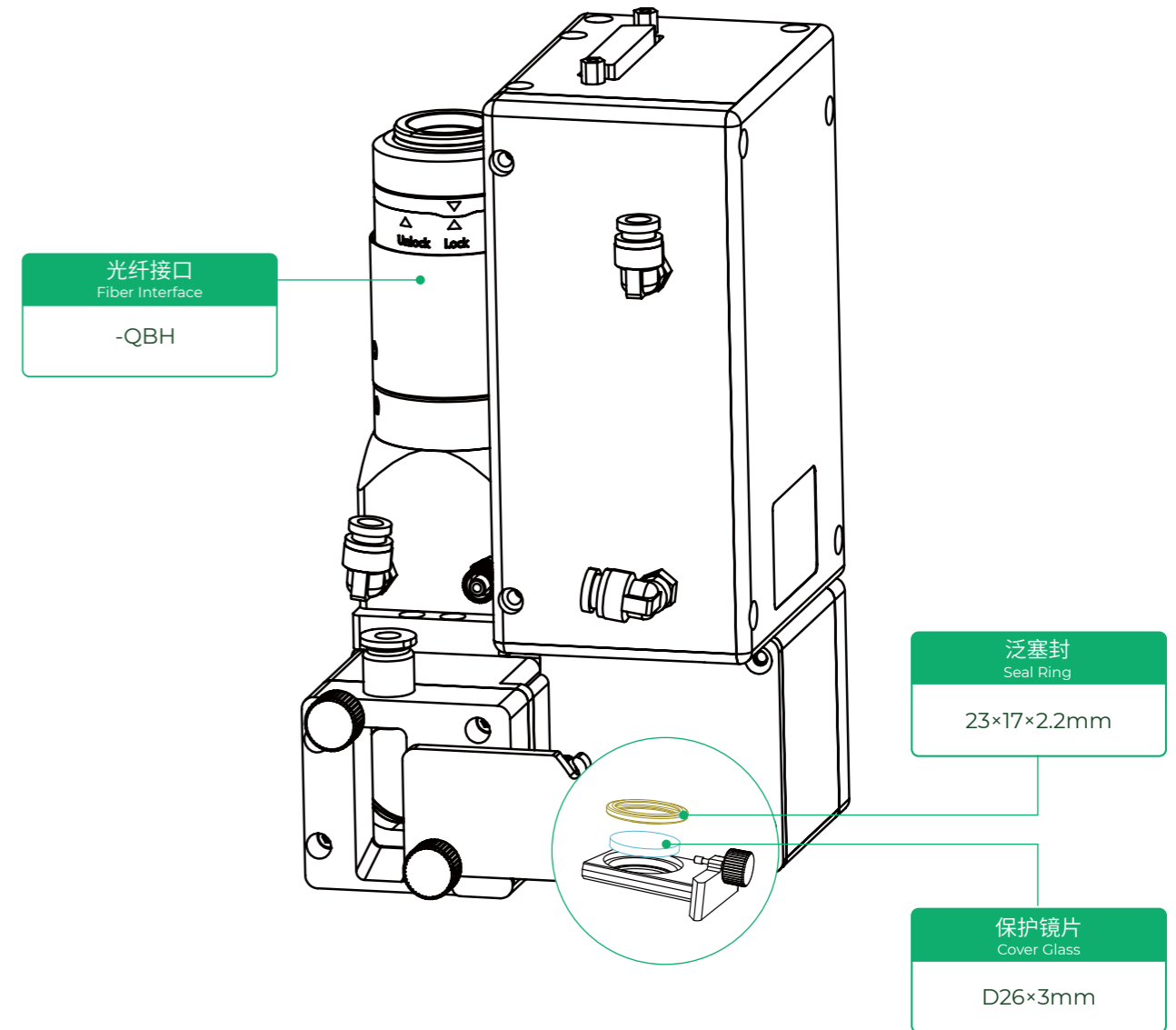

# BW420

连续可调矩形光斑封边头

Adjustable Rectangular Spot Banding Head

功率等级 **4kW**

Power Rating



更多信息请扫描二维码  
Scan it for more details

## 工艺优点

Process Advantages

全幅面能量均匀分布, 加工一致性高, 光斑连续电动调节, 光斑变化范围为 5mm\*10mm~5mm\*40mm, 适应性好

Uniform energy distribution as a whole, high processing consistency, and strong adaptability with continuous spot adjustment electrically from 5mm\*10mm to 5mm\*40mm.

## 高度防尘

Excellent Dustproof

牢靠的密封性设计, 可以有效避免光学镜片污染, 提高使用寿命

Reliable sealing design to avoid contamination to optical lens and prolong the lifespan.



\*产品图片仅供参考

## 带有实时闭环温度监控

Real-time Closed-loop Temperature Control

使用过程中实时对熔池温度进行监控, 并反馈给激光器调节激光器功率

The temperature of the molten pool is monitored in real time during use, and the laser power is adjusted by feedback to the laser.

## 高效冷却

Efficient Cooling

双水冷结构设计, 保护镜座及激光头本体带有水冷接口, 延长持续工作时长

Double water-cooled structure design, the lens holder and the laser head body are equipped with water-cooled interface to extend the working duration.

## 技术参数 Specifications

激光波长 Laser Wavelength	光纤1064mm
光纤接口 Fiber Interface	QBH
通光孔径 Clear Aperture	35mm
准直镜焦距 Collimator Focal Length	100mm
聚焦镜焦距 Focusing Focal Length	400mm
保护镜片 Cover Glass	
- 准直保护 Collimation Side	Φ37mm×1.6mm
- 聚焦保护 Focusing Side	Φ37mm×7mm
焦点调节范围 Focus Adjustment Range	±30mm
重复定位精度 Repeatability	≤0.1mm
光斑尺寸 Spot Size	5mm*10mm~5mm*40mm
测量精度 Measurement Accuracy	0.4%

响应时间 Response Time	1ms
辅助气体气压 Assist Gas Pressure	6bar
重量 Weight	~6.0kg

### 可调矩形光斑示例

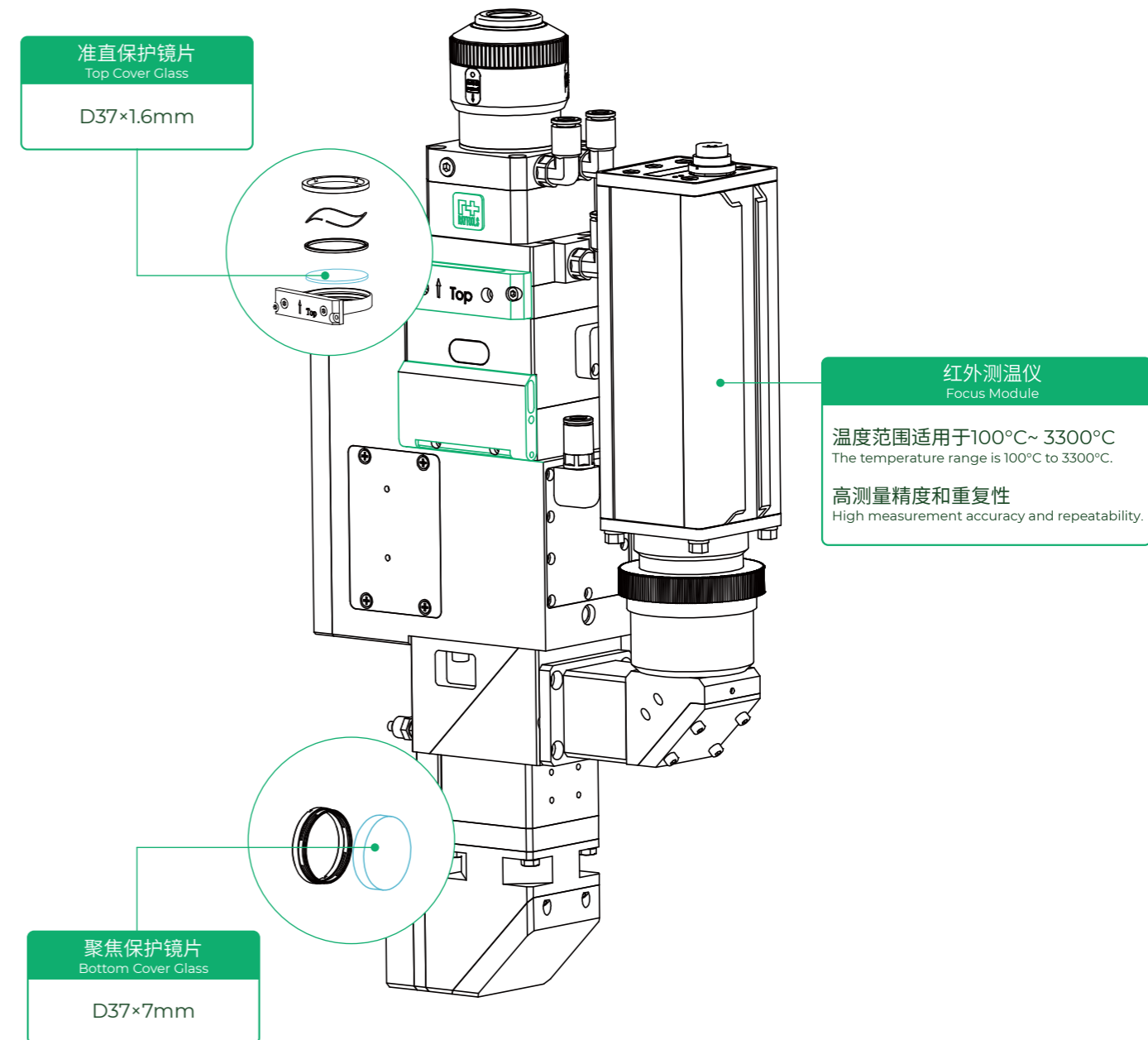
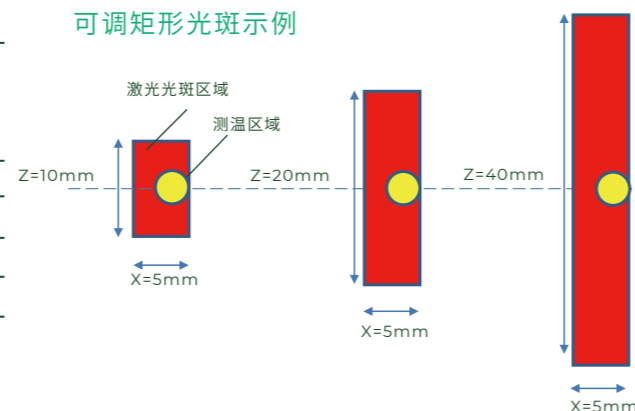



# AK090-4FA

固定矩形光斑封边头

Fixed Rectangular Spot Banding Head

功率等级

Power Rating

4kW



更多信息请扫描二维码  
Scan to get details

## 固定矩形光斑封边头

Fixed Rectangular Spot Banding Head

适应于单品类大批量加工需求,纯光学设计将圆形高斯光斑转换为矩形平顶光斑,参数调整简单方便,长期加工可靠性高

Adapted to batch processing of single product categories; Circular Gaussian spots rather than rectangular flat-topped spots with an optical design; convenient adjustment for parameters and high reliability for long-term processing.



\*产品图片仅供参考  
\* For Reference Only

## 精巧的结构设计

Ingenious Structural Design

整体尺寸小,重量轻巧,安装方便,镜片直接冷却,加工稳定性高

Small size, lightweight, convenient installation with direct cooling of the lenses and high processing stability.

## 矩形平顶能量分布

Rectangular Flat-top Beam Distribution Mode

光斑形状可进行定制化设计,矩形光束能量分布均匀,封边一致性高

Customization for the spot shape; uniform energy distribution of the rectangular beam and high consistency of banding.

## 镜头适应性广

Wide adaptability for lens

大通光孔径,宽波段镀膜,可适配光纤和半导体激光器

Large clear aperture and broadband coating, adaptable to fiber and semiconductor lasers.

## 技术参数 Technical Data

功率等级 Power Rating	4000W
----------------------	-------

激光波长 Laser Wavelength	900-1100nm
--------------------------	------------

光斑尺寸 Spot Size	矩形光斑,尺寸可定制
-------------------	------------

重量 Weight	~3.0kg
--------------	--------

光纤接口  
Fiber Interface

- QBH
- QD

保护镜组件  
Protective Mirror Assembly

标配  
Standard configuration

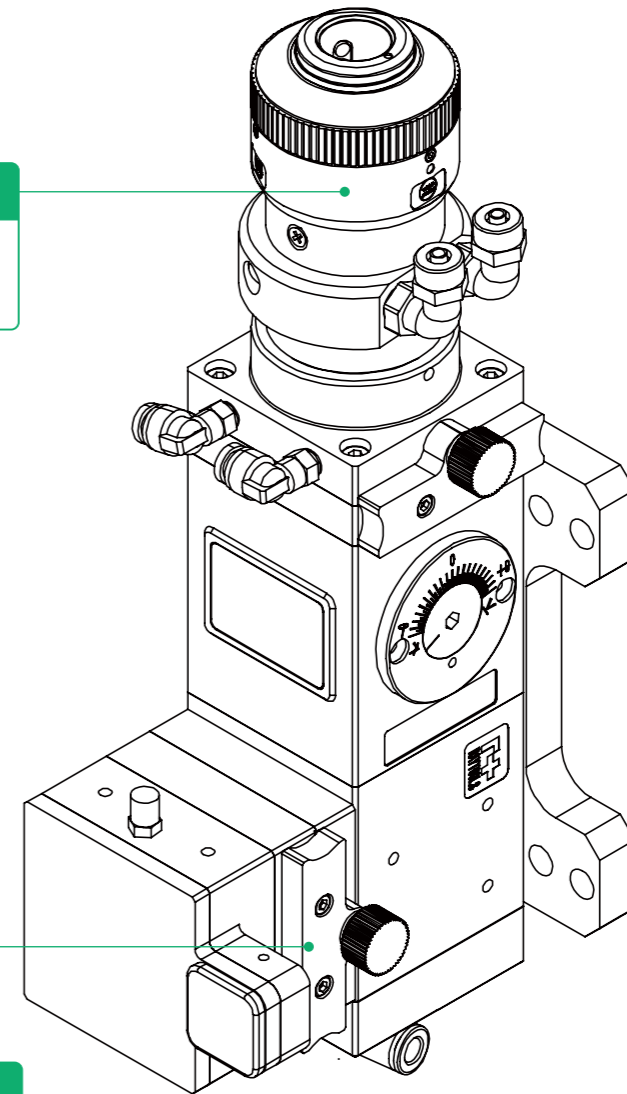

# AK090-4FB

可调矩形光斑封边头

Adjustable Rectangular Spot Laser Banding Head

功率等级

Power Rating

4kW

更多信息请扫描二维码

Scan to get details



## 可调矩形光斑封边头

Adjustable Rectangular Spot Banding Head

基于纯光学设计将圆形高斯光斑转换为矩形平顶光斑,可同时满足多种板厚的加工需求,光束自动切换,长期使用稳定性高

Circular Gaussian spots rather than rectangular flat-topped spots with an optical design, supporting for machining sheets of different thicknesses, with automatic beam switching function and high stability for long-term use parameters and quick switching for parameter storage.



\*产品图片仅供参考  
\* For Reference Only

## 加工可靠性高

High Reliability for Processing

镜片直接冷却,纯光学设计,无须其它电动装置实现光束尺寸变化,加工稳定性高

The Direct cooling function of the lens with an optical design and high processing stability, unnecessary for motorized devices to change the beam size.

## 矩形平顶能量分布

Rectangular Flat-top Beam Distribution Mode

光斑形状可进行定制化设计,矩形光束能量分布均匀,封边一致性高

Customization for the spot shape; uniform energy distribution of the rectangular beam and high consistency of banding.

## 镜头适应性广

Wide Adaptability for Lens

大通光孔径,宽波段镀膜,可适配光纤和半导体激光器,多光束实现自动切换

Large clear aperture and broadband coating, adaptable to fiber and semiconductor lasers with multiple beams for automatic switching.

光纤接口  
Fiber Interface

- QBH
- QD
- LLK-D

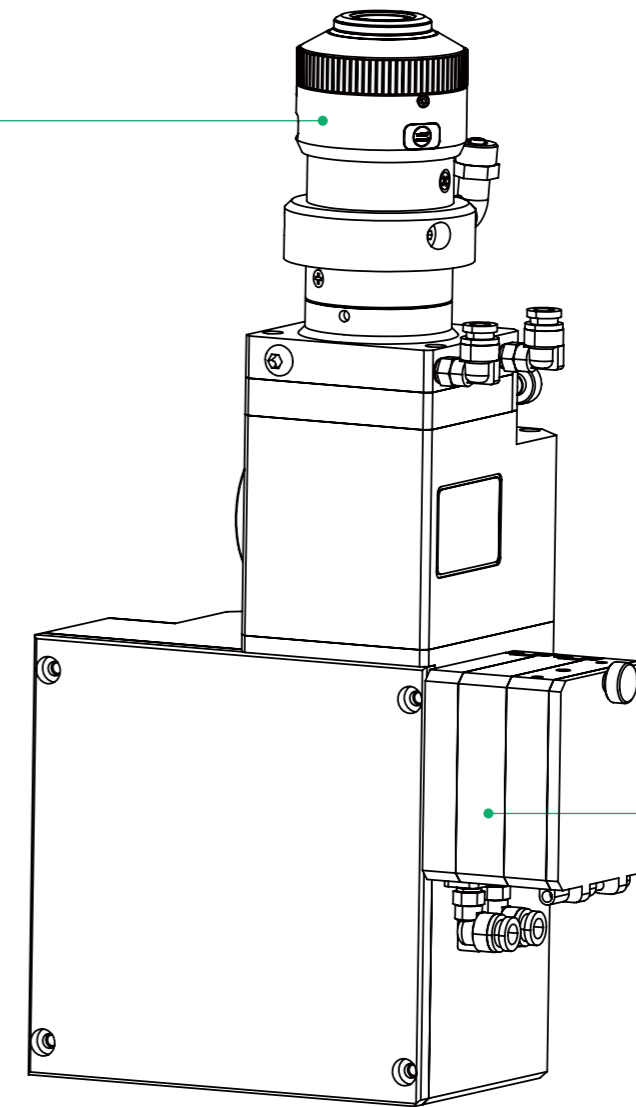

双保护镜组  
Double Protective Lens Group

标配  
Standard configuration

## 技术参数 Technical Data

功率等级 Power Rating	4000W
激光波长 Laser Wavelength	900-1100nm

光斑尺寸 Spot Size	矩形光斑,多挡可调
重量 Weight	~6.0kg

# AK090-4FC

连续可调矩形光斑封边头

Continuously Adjustable Rectangular Spot Banding Head

功率等级

Power Rating

4kW

更多信息请扫描二维码

Scan to get details



## 连续可调矩形光斑封边头

Continuously Adjustable Rectangular Spot Banding Head

基于纯光学设计全幅面光束匀化,可同时满足10-60mm板厚的封边加工需求,光束自动连续调节,长期使用稳定性高

Circular Gaussian spots rather than rectangular flat-topped spots with an optical design, supporting banding processing of 10-60 mm sheet; automatic beam switching function and high stability for long-term use.



\*产品图片仅供参考  
\* For Reference Only

## 可调幅度大,应用范围广泛

Wide Applications and Large Adjustable Range

10-60mm范围光束连续可调,可覆盖目前激光封边主流板厚需求

Continuously adjustable beams from 10 to 60 mm, meeting major demands for laser banding in market.

## 矩形平顶能量分布

Rectangular Flat-top Beam Distribution Mode

矩形光束全幅面能量均匀分布,封边一致性高

Uniform energy distribution of the rectangular beam and high consistency of banding

## 镜头全密封设计,拓展功能多

The Sealed Lens with various expanding functions

高效冷却、全密封结构,可选配全闭环温度监控系统,视觉系统等,确保加工过程稳定可靠  
Efficient cooling function and sealed structure, optional fully close-loop temperature monitoring system, vision system, etc., to provide stable and reliable processing.

## 技术参数 Technical Data

功率等级 Power Rating	4000W
激光波长 Laser Wavelength	900-1100nm

光斑尺寸 Spot Size	10-60mm连续可调 (F400mm)
重量 Weight	~6.0kg

光纤接口  
Fiber Interface

-QBH  
-QD

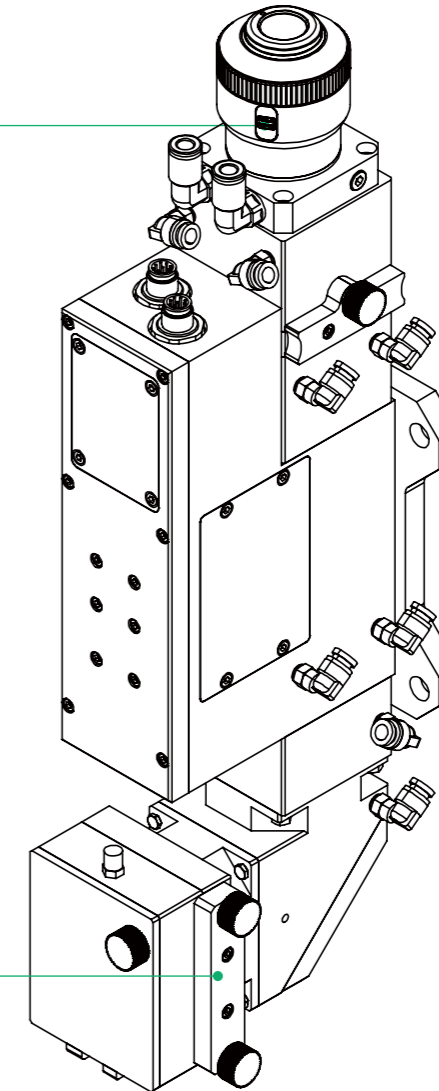

保护镜组件  
Protective Mirror Assembly

标配  
Standard configuration

# 焊接控制系统 Welding Control System

## 功能界面 Function Interfaces

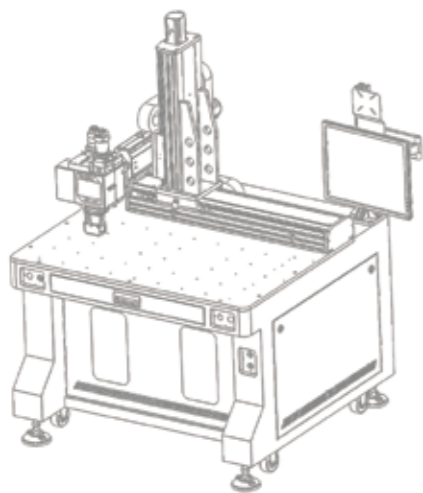

可运用在焊接平台或机器人的功能界面展示

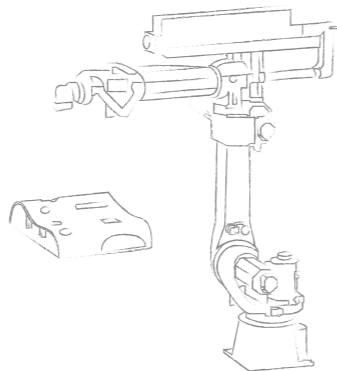

Applicable to display the operation interface of welding platform and robot welding.



可用于多轴运动式焊接场景或机器人  
焊接场景的典型焊接头

Typical laser welding head: mostly applicable to the multi-axis motion welding and robot welding.

## 适配焊接头

BF320	BF330-4F	BF330-6C
		
<b>应用场景</b> Application	<b>应用场景</b> Application	<b>应用场景</b> Application
3C行业焊接 3C Industry	钣金焊接 Sheet Metal	大幅面高速焊接 High-speed for Large Area
薄板焊接 Thin Plate	高反材料焊接 High-reflection Materials	新能源行业焊接 New Energy Source Industry
<b>功率等级</b> Power Rating	<b>功率等级</b> Power Rating	<b>功率等级</b> Power Rating
3kW	4kW	6kW

## 特点 Features

XW-100激光焊接系统 XW-100 Laser Welding System	
<b>工艺特点</b> Process Feature	支持缓升缓降调节, 优化起步和结束点工艺 Adjustment of laser power ascent and descent, optimized start and end technique.
	支持功率曲线调节, 拐角工艺处理 Power curve adjustable and corner treatment.
	独特的PSO功能, 均匀的分布焊接过程的能量, 焊缝的一致性较好 With unique PSO function, uniform distribution of energy in welding process, and good welding consistency.
<b>控制特点</b> Control Feature	支持控制多款振镜焊接头, 光斑控制等 Able to control multiple types of galvo laser welding heads and spot.
	支持EtherCAT总线伺服, 支持脉冲控制伺服 Both EtherCAT serial bus servo and pulse controlled servo applicable.
	支持多轴运动, 多工位控制 Multi-axis motion and multi position control.
	支持手轮示教, 界面示教, 导图等加工处理 With processing modes like teaching mode of hand-wheel and interface, and image inputting.
	支持在线查阅报警信息, 可直接查看对应报警信息的解决办法 Checking the alarm information online and looking up the corresponding.
	直观的监控界面, 便于监控信号 With intuitive monitoring interface, easy to monitor signals.
支持灵活配置用户自定义输入输出 Flexible configurations for user defined input and output.	



# 新能源焊接平台PL5050

## New Energy Welding Station



\*产品图片仅供参考  
\* For Reference Only

## 技术参数 Technical Data

焊接头 Welding Head	用户自定义 User Defined	运行速度 Processing Speed	≤1000mm/s
平台加工范围 Platform Processing Range	500×500×200mm	运行加速度 Processing Acceleration	< 5g (可定制)
定位精度 Positioning Accuracy	±4um	平台尺寸 Size	1200×1200×1900mm
重复定位精度 Repeated Positioning	±2um	重量 Weight	1000kg

大理石底座+THK直线导轨保证平台稳定可靠

Marble base +THK linear guide ensure a stable and reliable station.

高性能DDL电机驱动技术,保证了良好的动态性能

High performance DDL motor drive technology ensures good dynamic performance.

雷尼绍光栅,全闭环控制

With Renishaw grating, fully close-loop control.

耐高温、全封闭式防护罩,适用于激光加工场景

With a heat-resistant and fully enclosed shield, fitting laser processing applications.

美国AheadTechs激光焊接专用总线系统

Laser welding specialized busfield control system from AheadTechs of America.

最大加速度可定制,最大速度可定制

Customizable maximum speed and acceleration.

支持缓升缓降调节,优化起步和结束点工艺

Adjustment of laser power ascent and descent, optimized start and end technique.

支持曲线功率调节,拐角工艺处理

Power curve adjustable and corner treatment.

独特的PSO功能,均匀的分布焊接过程能量,焊接一致性好

With unique PSO function, uniform distribution of energy in welding process, and good welding consistency.

支持手轮示教,界面示教,导图等加工处理

With processing modes like teaching mode of hand-wheel and interface, and image inputting.

支持在线查阅报警信息,可直接查看对应报警信息的解决办法

Checking the alarm information online and looking up the corresponding solution directly.

直观的监控界面,便于控制信号

With intuitive monitoring interface, easy to control signals.

支持灵活配置用户自定义输入输出

Flexible configurations for user-defined input and output.

# 熔覆解决方案 Cladding Solution

## EMP-MLP多功能激光加工单元

EMP-MLP Multifunctional Laser Processing Station



\*产品图片仅供参考  
\* For Reference Only

### 技术参数 Technical Data

可实现功能 Function	激光焊接、熔覆、淬火快速切换 Fast switching between laser welding, cladding and hardening
激光光源 Laser Light Source	光纤/半导体激光器 Fiber/Diode Laser
功率范围 Power Rating	1000-6000W (更高功率可定制) For Higher Power Rating: Customizable
激光波长 Laser Wavelength	900-1100nm
定位精度 Positioning Accuracy	±0.1mm
重复定位精度 Repeated Positioning Accuracy	±0.05mm
运行速度 Processing Speed	≤200mm/s
工作范围 Processing Range	600×400×300mm (可定制) (Customizable)

适配嘉强自主开发数控系统, 可满足定功能及界面定制化需求

Applicable to the CNC system independently developed by RayTools and able to meet the needs of certain functions and customized interfaces.

可根据应用需求提供精密伺服或者大理石直线电机运动单元, 性价比高

Cost effective for providing high precision servo or marble linear motor according to application requirements.

可选配AB轴运动模块, 实现直线、圆形、曲线、曲面以及五轴加工运动轨迹, 应用范围广泛

A wide range of applications based on optional AB axis motion units to enable a variety of motion tracks in processing, including lines, circles, curves, surfaces and five axis.

耐高温、全封闭式防护罩, 适用于激光加工场景

With a heat-resistant and fully enclosed shield, fitting laser processing applications.

配置嘉强自主开发多功能激光加工头, 在不更换光源及光学器件下实现激光焊接、熔覆、淬火三种功率的快速切换, 特别适用于前期工艺测试及科研应用需求

Equipped with multi-functional laser processing head independently developed by RayTools, fast switching among laser welding, cladding and hardening-with different power rating without replacing light source and optical device, perfect for initial processing tests and scientific researches.

送粉喷嘴配置 Powder Feeding Nozzle Configuration	三路、四路、环形、高速、宽带、内孔喷嘴可选 3-way, 4-way, Annular, High-speed, Wideband, Inner hole nozzle - Optional
淬火尺寸 Quenching Size	5×5mm、10×2mm、15×2mm、20×4mm等(可定制) (Customizable)
焦点光斑(焊接、熔覆用) Focal Spot (for welding and cladding)	可手动快速可调, 调整范围可定制 Manual Adjustment Available; Adjustable Range Customizable
双轴转台 Two-axis Turntable	可配(配置对应数控单元) Configurable
惰性气体箱体 Inert Gas Chamber	可配 Configurable
安全监控单元 Safety Monitoring Module	加工监测摄像、安全门报警、加工头防碰撞单元等可配 Processing monitoring camera, Safety door alarm, Processing head anti-collision module - Configurable
过程实时监控单元 Real-time Process Monitoring Module	红外测温、温度闭环控制、高速摄像单元等可配 Modules include infrared temperature measurement, Closed loop temperature control, High-speed camera, etc. - Configurable

可适用于铁基、镍基、铜基、铝基、钛基等多种金属材料的加工

Applicable to the processing of a variety of metal materials, including iron base, nickel base, copper base, aluminum base, titanium base, etc.

可选配进出工作台以及相应工装夹具, 满足定制化、批量化加工

optional in-and-out workbench and corresponding fixture for customizations and batch processing.

封闭式钣金结构, 搭配视频监控、防碰撞模块、镜片高温报警及气体压力报警等, 可选配APP实时性能监测单元, 确保加工过程人机安全

Enclosed sheet metal structure, with video monitoring, anti-collision module, lens high temperature alarm and gas pressure alarm, etc., optional APP real-time performance monitoring unit, to ensure human security and machine safety in processing.

# 精细管材激光加工解决方案

## Laser Processing Solution for Precision Tube



\*产品图片仅供参考  
\* For Reference Only

大理石底座+THK直线导轨保证平台稳定可靠

Marble base +THK linear guide ensure a stable and reliable platform.

高性能DDL电机驱动技术,保证了良好的动态性能

High performance DDL motor drive technology ensures good dynamic performance.

FAGOR光栅,全闭环控制

With FAGOR grating and fully enclosed loop control.

耐高温、全封闭式防护罩,适用于激光加工场景

High temperature resistant, fully enclosed protective cover, suitable for laser processing scenes.

RayTools定制精细管材激光切割头

Customized laser cutting head from RayTools for precision tubes.

美国AheadTechs激光切管专用总线系统

Laser tube cutting, specialized busfield system from AheadTechs of America.

可适用于碳钢、不锈钢、铜、Ni-Ti等各类金属

Suitable for carbon steel, stainless steel, copper, Ni-Ti and other metals.

切缝±10um

±10 um kerf width.



## 技术参数 Technical Data

功率等级 Power Rating	≤2000W	运行速度 Processing Speed	≤800mm/s
圆管加工范围 Round Tube Processing Range	直径1mm~10mm(可定制卡盘) (Customizable Chuck)	运行加速度 Processing Acceleration	≤0.8g
长度范围 Length Range	≤6500mm	平台尺寸 Size	1360×1200×1780mm
定位精度 Positioning Accuracy	±4um	重量 Weight	1000kg
重复定位精度 Repeated Positioning Accuracy	±2um		

# 送粉器

EMP-PF-2-1  
Powder Feeder

功率等级 1kW  
Power Rating

## 送粉速度可调

Adjustable Powder Feeding Speed

气体将粉末输送至加工区域，通过调节转盘转速和粉盘尺寸调节送粉速度

The powder will be transported to the processing area by gas. Adjust the powder feeding speed by adjusting the rotary speed and the powder plate size.

## 送粉精度高

High Accuracy of Powder Feeding

本设备双筒送粉，独立可控采用高精度伺服电机，送粉精度高

The powder feeder is independent and controllable. With double-way of powder feeding and the high precision servo motor, it has high precision powder feeding.



\*产品图片仅供参考  
\* For Reference Only

## 界面可定制

Customizable Interface

界面可以根据客户要求进行个性化定制

The interface can be customized according to customer's requirements.

## 高稳定性

High Stability

具有内控和外控两种操作模式和压力报警功能，最大程度满足客户稳定性加工需求

With internal control and external control of two operating modes and pressure alarm function, mostly meet the needs of processing stability.

## 技术参数 Technical Data

功率等级 Power Rating	≤1000W	可送粉末粒度 Powder Size	20-200μ
送粉筒 Powder Feeding Funnel	双筒送粉, PLC独立可控 Two-way, independent and controllable PLC	送粉盘转速 Feeding Plate Speed	0-20转/分钟无级调速 0-20 rpm CV
外形尺寸 Size	600×500×1450mm(W×D×H)	送粉重复精度 Re-send Powder Precision	<±2%
输入 Input	220VAC, 50HZ	所需气源 Gas Supply	氮气/氩气 Nitrogen/Argon

# 焊接寻位系统

BI 100

Weld Seam Tracking

具有寻位与跟踪的功能，既满足高效定位又适合过程矫正

Positioning and tracking functions enable efficient positioning and deviation reduction.

有效排除焊接强光及烟尘干扰等，使产品能够适应恶劣的视觉环境

Effective elimination of strong light and smoke interference enables the product to adapt to harsh visual environment.

连接KUKA、FANUC、ABB、YASKAWA等机器人，具有自动标定程序嵌入式指令，操作便捷示教简单

Connecting with KUKA, FANUC, ABB, YASKAWA and other robots, with auto calibration embedded order, easy to operate and simple to teach.



\*产品图片仅供参考  
\* For Reference Only

可与BW产线焊接头完美配合

Perfect match with BW Series welding head.

## 技术参数 Technical Data

有效视距 Visibility Range	100~200mm	检测周期 Detection Cycle	10ms
检测范围 Detection Range	±17mm	使用环境 Ambient Temperature	-10°C~40°C
焊缝宽度 Weld Width	0.5~15mm	外形尺寸 Size	94×41×100mm
检测精度 Accuracy	0.05mm	重量 Weight	0.65kg



# 测温模块

BI 200

Laser Pyrometer

激光淬火、熔覆及表面处理等闭环温度控制，可以精确地保持边缘、突出或孔的硬化温度

Closed-loop temperature control, such as laser hardening, cladding and surface treatment, can accurately maintain the hardening temperature of edges, protrusions or holes.

测试温度范围为700°C~2300°C

The test temperature range is from 700°C to 2300°C.



\*产品图片仅供参考  
\* For Reference Only

具有用于过程设置、可视化和数据存储的强大软件包

Powerful software packages for process setup, visualization, and data storage.

闭环控制，最高可达10kHz

Closed-loop control, up to 10kHz.

具有24V数字和模拟0~10V I/O的工业I/O终端用于自动化线路的集成和激光器的连接

Industrial I/O terminals with 24V digital and 0-10V analog I/O for automation line integration and laser connection.

## 技术参数 Technical Data

温度范围 Temperature Range	700°C-2300°	环境温度 Ambient Temperature	
光谱范围 Spectral Range	1.45 - 1.8μm	- 控制器 Controller	MAX 40°C
检测精度 Accuracy	<1500°C, ±2°C	- 光学镜头 Optical Lens	MAX 60°C
最大采样频率 Maximum Frequency	0.1ms (10kHz)	光纤长度 Fiber Length	5m, 10m, 20m, 40m, 定制 (Customization)
响应时间 Response Time	< 0.2ms	外形尺寸 Size	94×41×100mm
重复精度 Repeated Accuracy	±1°C	重量 Weight	~2.0kg

# 红光指示器

Aiming Laser



型号 Model	光源 Light
120141710A	红光 Red Laser

# CCD成像辅助

CCD Imaging Assistant

型号 Model	规格 Specification
3570010127	VGA线10m(高柔) VGA Cable 10m(Highly Flexible)
3530020025	8英寸显示屏 8-inch Display
110253ACF0011	CCD相机 CCD Camera

# 准直组件 Collimation Module



型号 Model	光纤接口 Fiber Interface	入射角度 Incident Angle	准直镜焦距 Collimation Length	准直镜直径 Dia of Lens	水冷 Water-cooling
120CM30045	QBH	0°	75	D28	有 Yes
120CM30034	QBH	0°	100	D30	-
120CM30052	QD	0°	100	D30	有 Yes
120CM30039	QBH	0°	100	D30	有 Yes
120CM30073	QBH	0°	125	D30	有 Yes
120CM30043	QBH	0°	125	D30	有 Yes
120CM30042	QBH	90°	125	D30	有 Yes
120610200C	QBH	0°	135	D38.1	有 Yes
120CM30072	QBH	0°	150	D28	有 Yes
120CM30062	QBH	0°	150	D30	有 Yes
120CM30044	QBH	0°	180	D30	有 Yes

更多配置可拨打咨询热线400-670-1510

Please call the hotline 400-670-1510 for more configuration.