

@202208

# LASER BEAM DELIVERY TOOLS

## | CUTTING



RAYTOOLS

# Empower OpenLaser Solution



## About Us

- General Purpose:** Evaluation, generation and application of laser beam and control software for industrial use; custom project, knowhow and services;
- Achievements:** Industrial lasers beam delivery and automation for various applications, hybrid application concepts of high power lasers, diodes, custom projects; modular laser source and machine concepts, components, accessories and unique beam alignment technology;
- Advantages:** Independent company with vast know-how and engineering skills on demand and in line with customer requirements;

# CONTENT

## / FLAT CUTTING

### BeamSmart Series

- 01 BS04k 4KW  
All-In-One Smart Laser Cutting Head
- 03 BS08K 8KW  
All-In-One Smart Laser Cutting Head
- 05 BS12K 12KW  
All-In-One Smart Laser Cutting Head

### BeamMotion Series

- 07 BM109 1.5KW  
Auto Focus Laser Cutting Head
- 08 BM111 3.3KW  
Auto Focus Laser Cutting Head
- 10 BM114 6KW  
Auto Focus Laser Cutting Head
- 12 BM06K 6KW  
Auto Focus Laser Cutting Head
- 14 BM111E 3.3KW  
Smart Laser Cutting Head-EtherCAT
- 15 BM114E 6KW  
Smart Laser Cutting Head-EtherCAT

### BeamTools Series

- 16 BT240S 3.3KW  
Manual Focus Laser Cutting Head

## / TUBE CUTTING

### BeamBlade Series

- 18 BD04K 4KW  
Auto Focus Tube Cutting Head
- 20 BD08K 8KW  
Tube Cutting Head

### GoFly Series

- 22 GF402 6KW  
4-Axis Tube Cutting Head

## / MICRO CUTTING

### FastMicro Series

- 23 FM220 2KW  
Micro Laser Cutting Head

## / ROBOT CUTTING

### GoFly Series

- 25 GF101 4KW  
Robotic Laser Cutting Head with Built-in Z Axis
- 26 GF101+GF102 4KW  
Robotic Laser Cutting Head with Built-in Z Axis and A/B Axis

### BeamTools Series

- 27 BT220RC+Motorized Slide 1.5KW  
Robotic Laser Cutting Head with External Z Axis

### BeamBlade Series

- 27 BD04K+Motorized Slide 4KW  
Auto Focus Robotic Laser Cutting Head with External Z Axis
- 27 BD08K+Motorized Slide 8KW  
Auto Focus Robotic Laser Cutting Head with External Z Axis

## / 5-AXIS 3D CUTTING

### GoFly Series

- 28 GF501 4KW  
5-Axis 3D Laser Cutting Head



# RAYTOOLS BS04K SERIES

Available Worldwide except China

All-In-One Smart Laser Cutting Head

Power Rating **4KW**



Auto focus control via 0-10V or EtherCAT

4-Color LED lamps to monitor interior status

Real-time status of cutting head could be accessed at mobile APP or CNC controller.

Real-time monitoring to focus position and ready status of bottom cover glass

USA/Germany/Japan made fused silica raw lens material.



Optimized optical configuration and smooth gas circuit

Optimized X/Y alignment knob to facilitate beam alignment.

Real-time monitoring to temperature of top/bottom cover glass, focus lens and cavity

Real-time monitoring to cutting gas pressure and cavity pressure.

Standard QBH/QD (LLK-D)/G5 interfaces to work with different fiber lasers

## Technical Data

Item	Specification
Wavelength	1080nm
Fiber interface	QBH, QD (LLK-D), G5
Power rating	4000W
Clear Aperture	28mm
Collimation length	100mm
Focusing length	150mm
Auto focus range	-16mm~ +12 mm

Item	Specification
Cover glass	
- Top	Φ24.9 mm * 1.5 mm
- Middle/Bottom	Φ30mm *5 mm
Assist gas pressure	≤25bar
Weight	~ 6.5kg
Operating Temperature	5°C -55°C
Humidity	30%-95% without condensation

\*Specifications are subject to change without notice

# RAYTOOLS BS04K SERIES

Available Worldwide except China

All-In-One Smart Laser Cutting Head

Power Rating 4KW

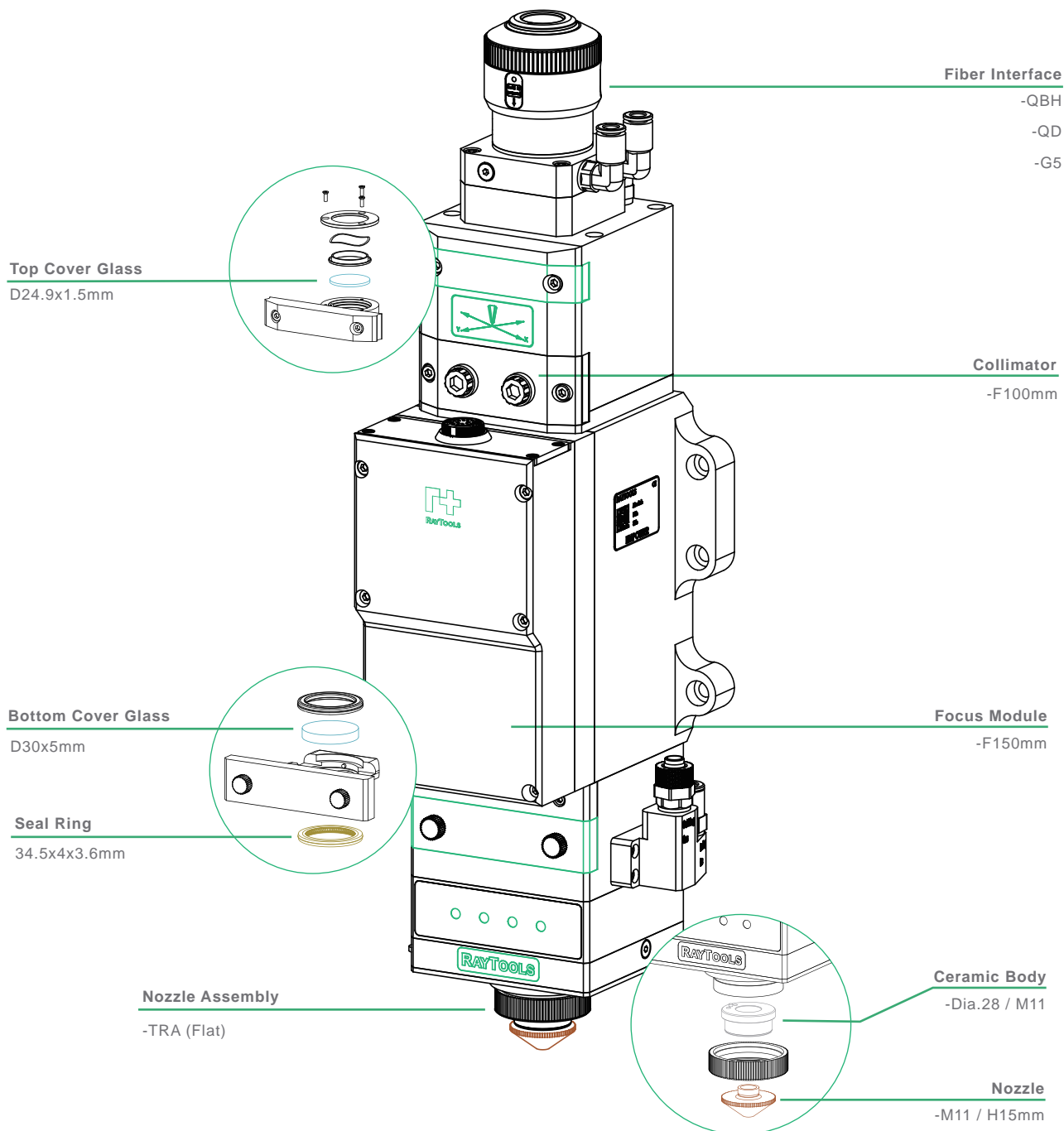

# RAYTOOLS BS08K SERIES

Available Worldwide except China

All-In-One Smart Laser Cutting Head

Power Rating **8KW**



---

Auto focus control via 0-10V or EtherCAT

---

4-Color LED lamps to monitor interior status

---

Real-time status of cutting head could be accessed at mobile APP or CNC controller.

---

Real-time monitoring to focus position and ready status of bottom cover glass

---

USA/Germany/Japan made fused silica raw lens material. High power rating of lens by 12000W.



---

Optimized optical configuration and smooth gas circuit

---

Optimized X/Y alignment knob to facilitate beam alignment.

---

Real-time monitoring to temperature of top/bottom cover glass, focus lens and cavity

---

Real-time monitoring to cutting gas pressure and cavity pressure.

---

Standard QBH/QD (LLK-D)/G5 interfaces to work with different fiber lasers

## Technical Data

Item	Specification
Wavelength	1080nm
Fiber interface	QBH, QD, G5
Power rating	8000W
NA max	0.13
Collimation length	100mm
Focusing length	150mm/200mm
Auto focus range	-26mm~ +16 mm (FL150); -52mm ~ +32mmmm (FL200)

Item	Specification
Cover glass	
- Top	Φ24.9 mm * 1.5 mm
- Middle/Bottom	Φ37mm *7 mm
Assist gas pressure	≤25bar
Weight	~ 8.2kg
Operating Temperature	5°C -55°C
Humidity	30%-95% without condensation

\*Specifications are subject to change without notice

# RAYTOOLS BS08K SERIES

Available Worldwide except China

All-In-One Smart Laser Cutting Head

Power Rating 8KW

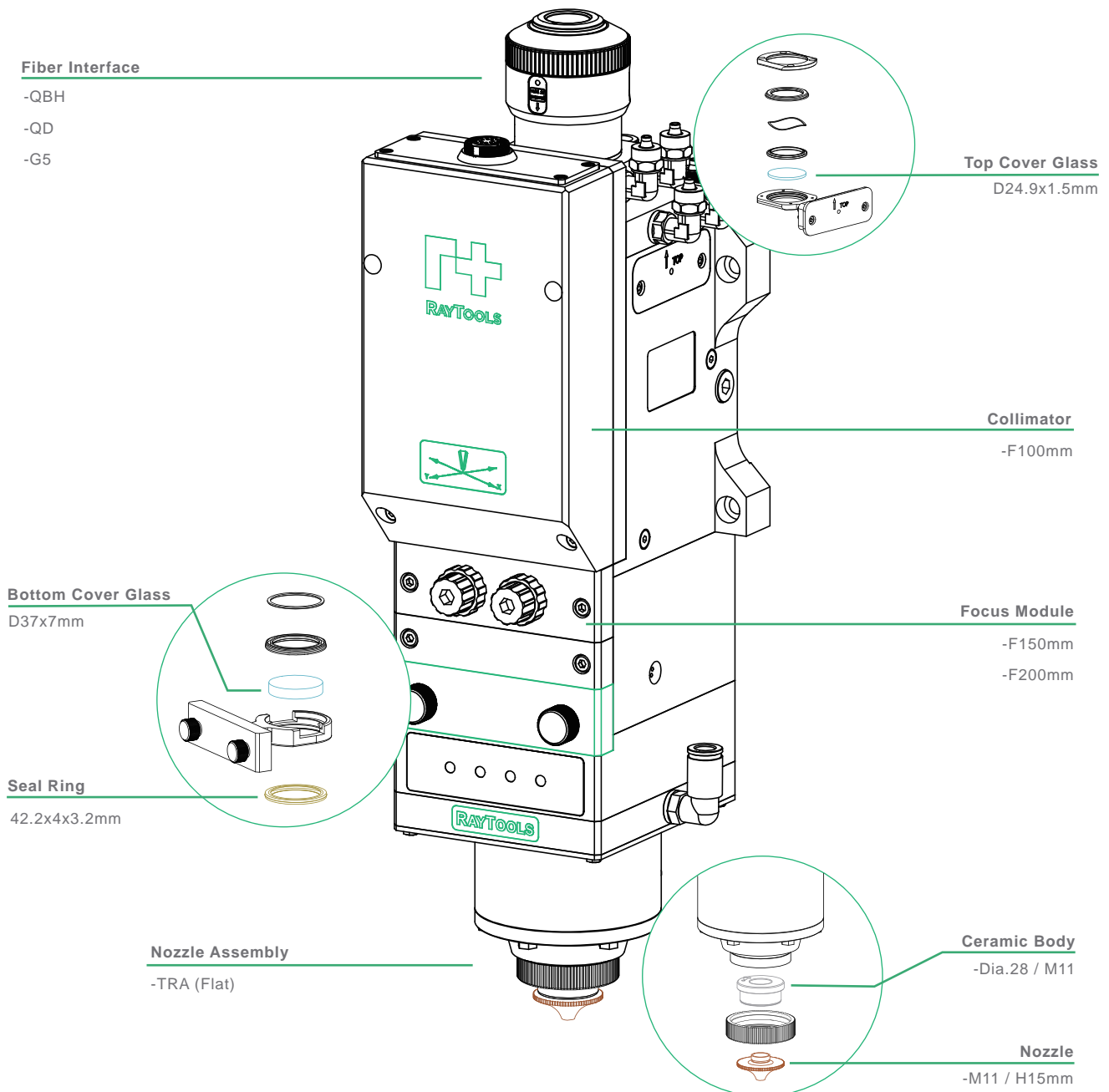

# RAYTOOLS BS12K SERIES



All-In-One Smart Laser Cutting Head

Power Rating **12KW**

Auto focus control via 0-10V or EtherCAT

4-Color LED lamps to monitor interior status

Real-time status of cutting head could be accessed at mobile APP or CNC controller.

Real-time monitoring to focus position and ready status of bottom cover glass

USA/Germany/Japan made fused silica raw lens material.



Optimized optical configuration and smooth gas circuit

Optimized X/Y alignment knob to facilitate beam alignment.

Real-time monitoring to temperature of top/bottom cover glass, focus lens and cavity

Real-time monitoring to cutting gas pressure and cavity pressure.

Standard QBH/QD/Q+/LOE interfaces to work with different fiber lasers

## Technical Data

Item	Specification
Wavelength	1080nm
Fiber interface	QBH, QD, Q+, LOE
Power rating	12000W
NA max	0.13
Collimation length	100mm
Focusing length	200mm
Auto focus range	-52mm ~ +32mmmm (FL200)

Item	Specification
Cover glass	
- Top	Φ24.9 mm * 1.5 mm
- Middle/Bottom	Φ37mm *7 mm
Assist gas pressure	≤30bar
Weight	~ 8.2kg
Operating Temperature	5°C -55°C
Humidity	30%-95% without condensation

\*Specifications are subject to change without notice



# RAYTOOLS BS12K SERIES



All-In-One Smart Laser Cutting Head

Power Rating 12KW

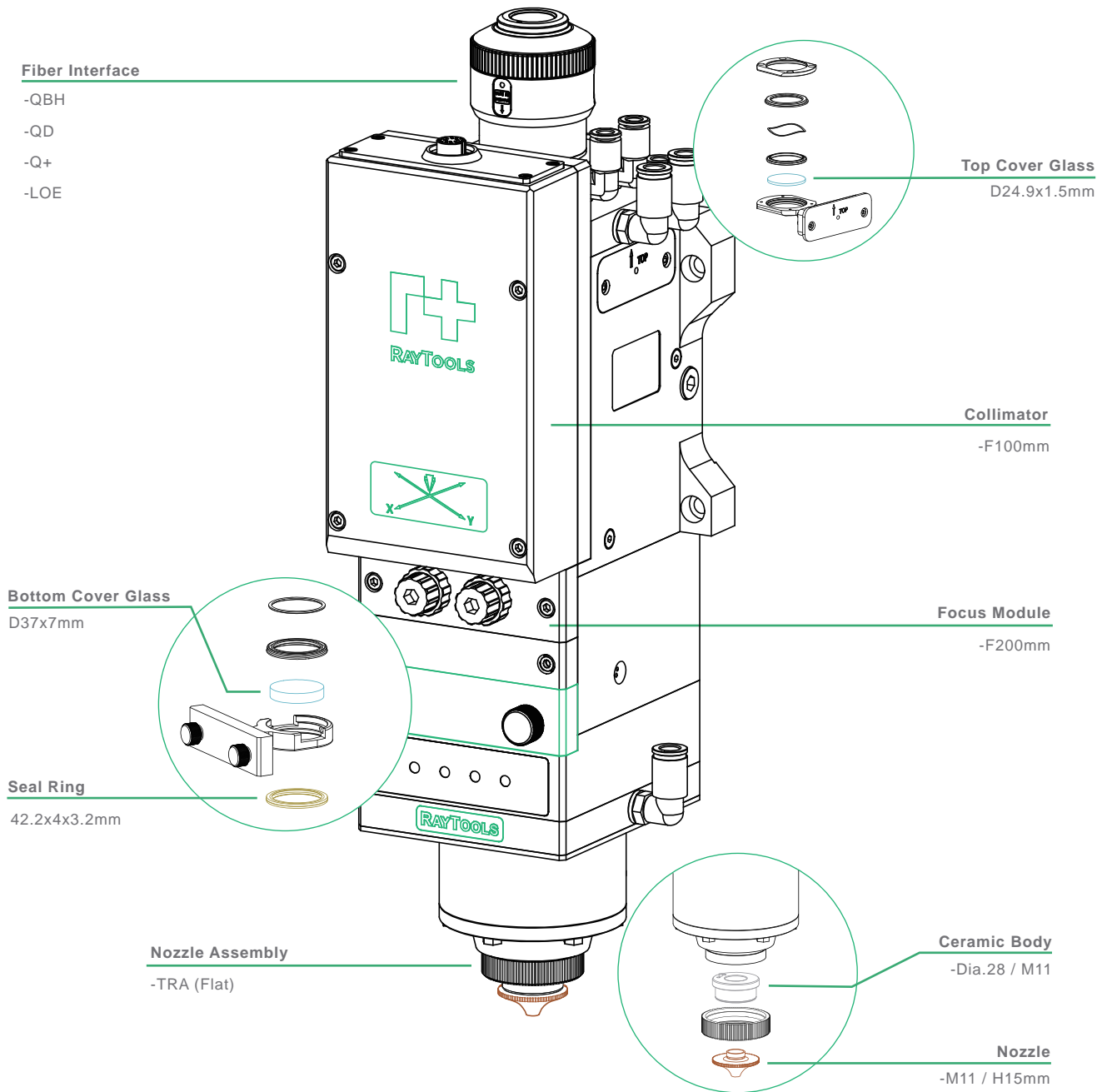

# RAYTOOLS BM109 SERIES



Auto Focus Laser Cutting Head

Power Rating 1.5KW

Modular design with easy maintenance.

3 Cover glasses (top, middle and bottom) to protect collimation & focus lens.

Dual water cooling circuits.



IP65 class dustproof, patented cover glass cover plate. All-around dust prevention.

Auto focus to reduce human intervention and improve piercing and cutting efficiency.

## Technical Data

Fiber Interface	QBH, QD
Clear Aperture	26 mm
Auto Focus	
- Range	+8 ~ -9 mm
- Acceleration	≤ 10 m/s <sup>2</sup>
- Velocity	≤ 6 m/min
- Accuracy	≤ 50 μm
Cover Glasses	
- Collimation Side (Top)	Φ24.9 * 1.5 mm
- Focusing Side (Bottom/Middle)	Φ27.9 * 4.1 mm

Collimation Length	100mm
Focus Length	125mm, 150mm
Nozzle Styles	Single, Double, Custom
Diameter of Nozzle Tip	0.8mm, 1.0mm, 1.2mm, 1.5mm, 2.0mm, 2.5mm, 3.0mm, 3.5mm, 4.0mm, 4.5mm, 5.0mm
Assist Gas Pressure	≤ 25 bar
Weight	~ 3 kg

Specifications subject to change without notice.

# RAYTOOLS BM111 SERIES

Auto Focus Laser Cutting Head

Power Rating **3.3KW**



Dual water cooling circuits.

Auto focus to reduce human intervention and improve piercing and cutting efficiency.

Modular design with easy maintenance.

3 Cover glasses (top, middle and bottom) to protect collimation & focus lens.

IP65 class dustproof, patented cover glass cover plate. All-around dust prevention.

## Technical Data

Fiber Interface	QBH, QD
Clear Aperture	28 mm
Auto Focus	
- Range	+10 ~ -12 mm
- Acceleration	≤ 10 m/s <sup>2</sup>
- Velocity	≤ 10 m/min
- Accuracy	≤ 50 μm
Cover Glasses	
- Collimation Side (Top)	Φ24.9 * 1.5 mm
- Focusing Side (Middle/Bottom)	Φ27.9 * 4.1 mm

Collimation Length	75mm, 100mm
Focusing Length	125mm, 155mm, 200mm
Nozzle Styles	Single, Double, Custom
Diameter of Nozzle tip	0.8mm, 1.0mm, 1.2mm, 1.5mm, 2.0mm, 2.5mm, 3.0mm, 3.5mm, 4.0mm, 4.5mm, 5.0mm
Assist Gas pressure	≤ 30 bar
Weight	~ 5.7 kg

Specifications subject to change without notice.

# RAYTOOLS BM111 SERIES

Auto Focus Laser Cutting Head

Power Rating 3.3KW

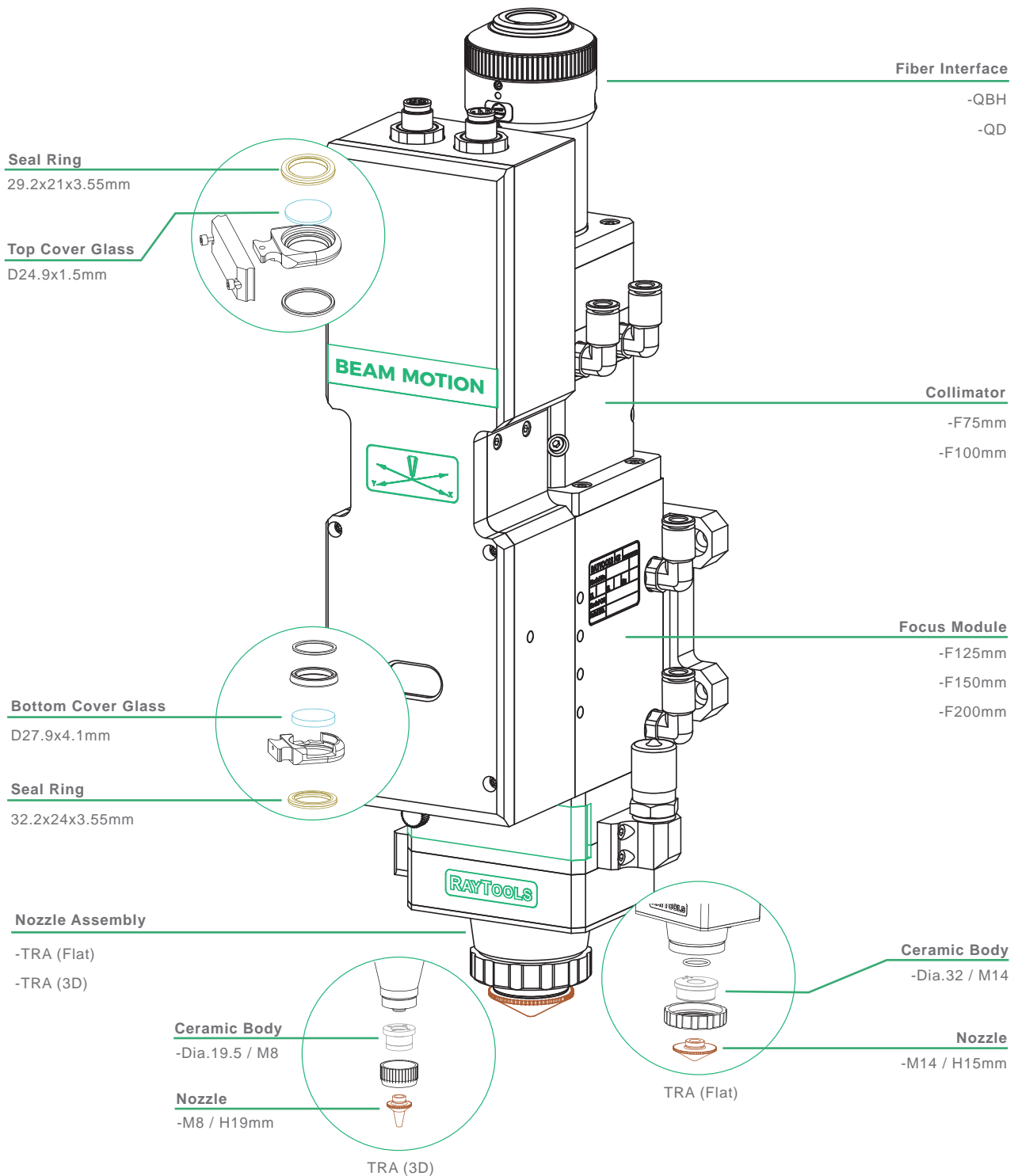

# RAYTOOLS BM114 SERIES



Auto Focus Laser Cutting Head

Power Rating **6KW**

Rated to 6kW @ 1um, with D37 lens combo for thick plate cutting.

Updated version from BM114S with improved design of optics systems and gas circuit.

Collimation and focusing lenses are both water cooled.

Compact design to reduce the payload of Z axis.

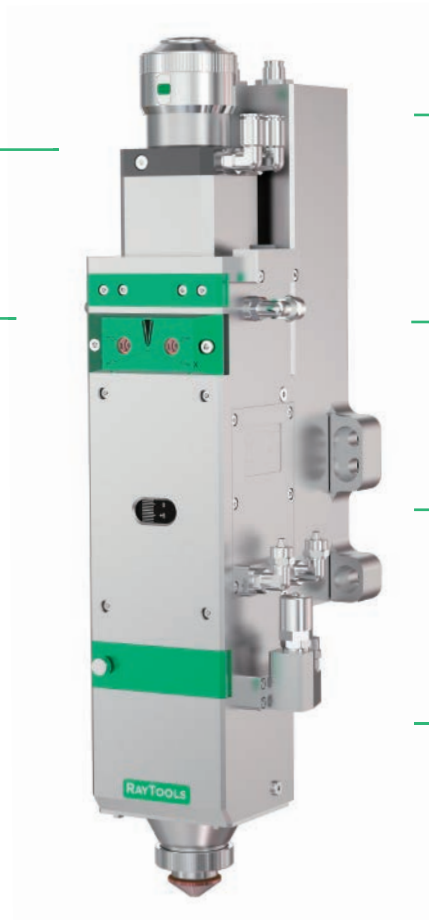

35mm Clear aperture which effectively reduces stray beam interference and guarantee cutting quality and lifespan.

Additional middle cover glass is equipped to prolong lifespan of focus lens.

Air cooling to nozzle which effectively protects the nozzle & ceramic part and extends the lifespan.

Auto focus by Yaskawa or AheadTechs Servo.

## Technical Data

Fiber Interface	QBH, QD, G5
Clear Aperture	35 mm
Auto focus	
- Range	+15 ~ -20 mm
- Acceleration	≤ 10 m/s <sup>2</sup>
- Velocity	≤ 10 m/min
- Accuracy	≤ 50 μm
Cover Glasses	
- Collimation Side (Top/Middle)	Φ37 * 1.6 mm
- Focusing Side (Bottom)	Φ37 * 7 mm

Collimation Length	100mm
Focusing Length	150mm, 200mm
Nozzle Styles	Single, Double, Custom
Diameter of Nozzle tip	
- Single	1.2~5 mm
- Double	1.0~1.8 mm
- Boost	1.6~7.0 mm
Assist gas pressure	≤ 30 bar
Weight	~ 5.6 kg

Specifications subject to change without notice.

# RAYTOOLS BM114 SERIES



Auto Focus Laser Cutting Head

Power Rating **6KW**

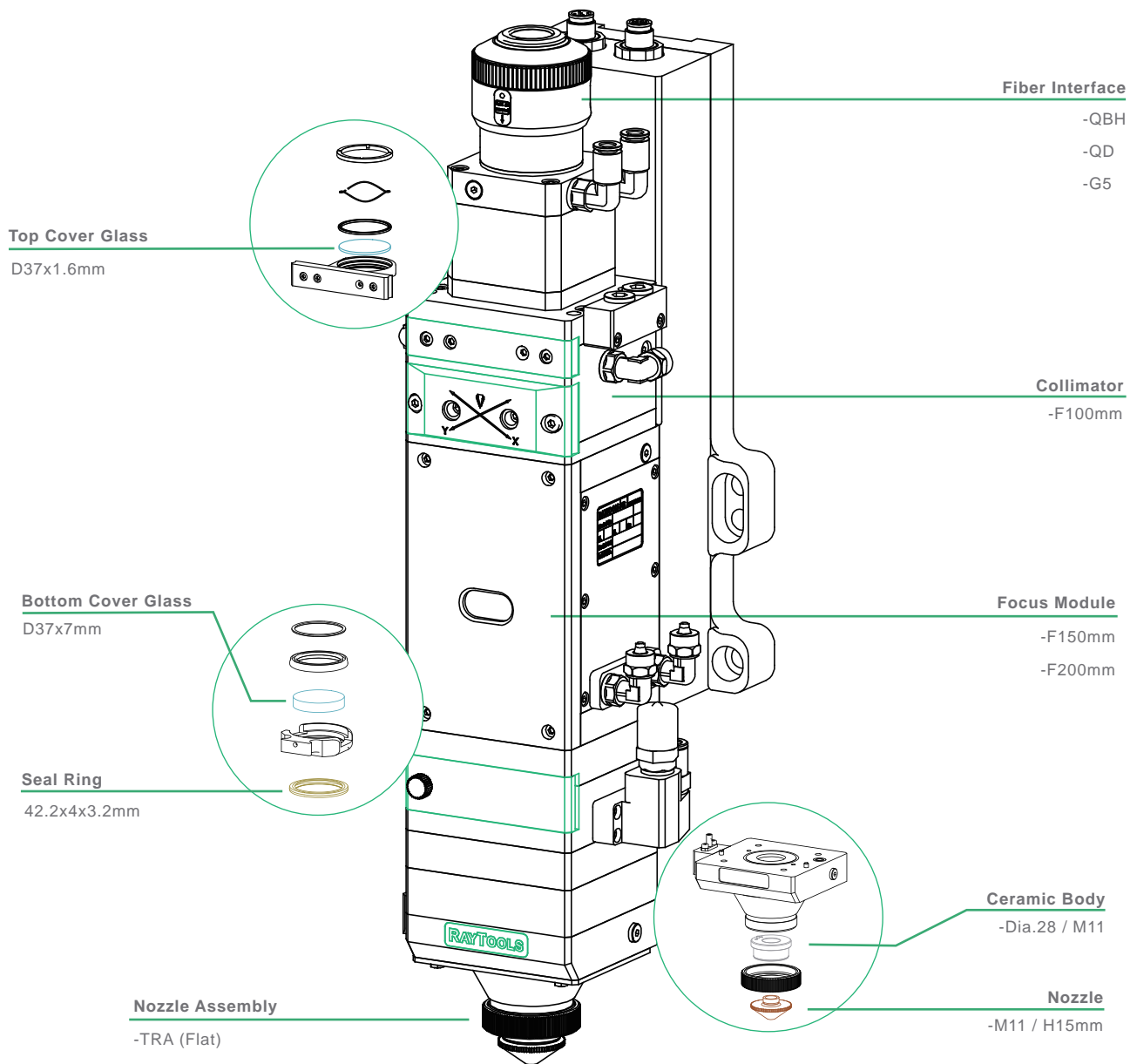

# RAYTOOLS BM06K SERIES



Auto Focus Laser Cutting Head

Power Rating **6KW**

### Efficient Cooling

Cooling structure for both collimation module and focus module, and air cooling to nozzle which effectively protects the nozzle & ceramic part and extends the lifespan.

### Multiple Cover Glasses

4 cover glasses designed to effectively decrease contamination risk during replacement of fiber & cover glass and extend the lifespan of collimation lens and focus lens.

### Fast Focusing

Auto focus by moving collimation lens to achieve higher speed and bigger auto focus range.



### Intelligent Monitoring

Monitoring to temperature of bottom cover glass could be accessed at mobile APP or computer desktop in real-time. Alarm output for overheating to protect the optical path system effectively.

### Optimized Structural Design

Integrated design to ensure sealing. Improved fiber interface(QBH, QD, G5) to benefit their compatibility of lasers and prevent from being stuck for leaks and rusts.

## Technical Data

Fiber Interface	QBH, QD, G5
NA	0.13
Auto Focus	
- Range	-35 ~ +25 mm
- Acceleration	≤ 10 m/s <sup>2</sup>
- Velocity	≤ 200 m/min
- Accuracy	≤ 10 μm
Cover Glasses	
- Collimation Side (Top)	Φ24.9 * 1.5 mm
- Focusing Side (Bottom/Middle)	Φ37 * 7 mm

Collimation Length	100mm
Focus Length	150mm, 200mm
Nozzle Styles	Single, Double, Boost
Diameter of Nozzle Tip	
- Single	1.2-5.0mm
- Double	1.0-1.8mm
- Boost	1.6-7.0mm
Assist Gas Pressure	≤ 30 bar
Weight	~ 7.5 kg

Specifications subject to change without notice.

# RAYTOOLS BM06K SERIES



Auto Focus Laser Cutting Head

Power Rating 6KW

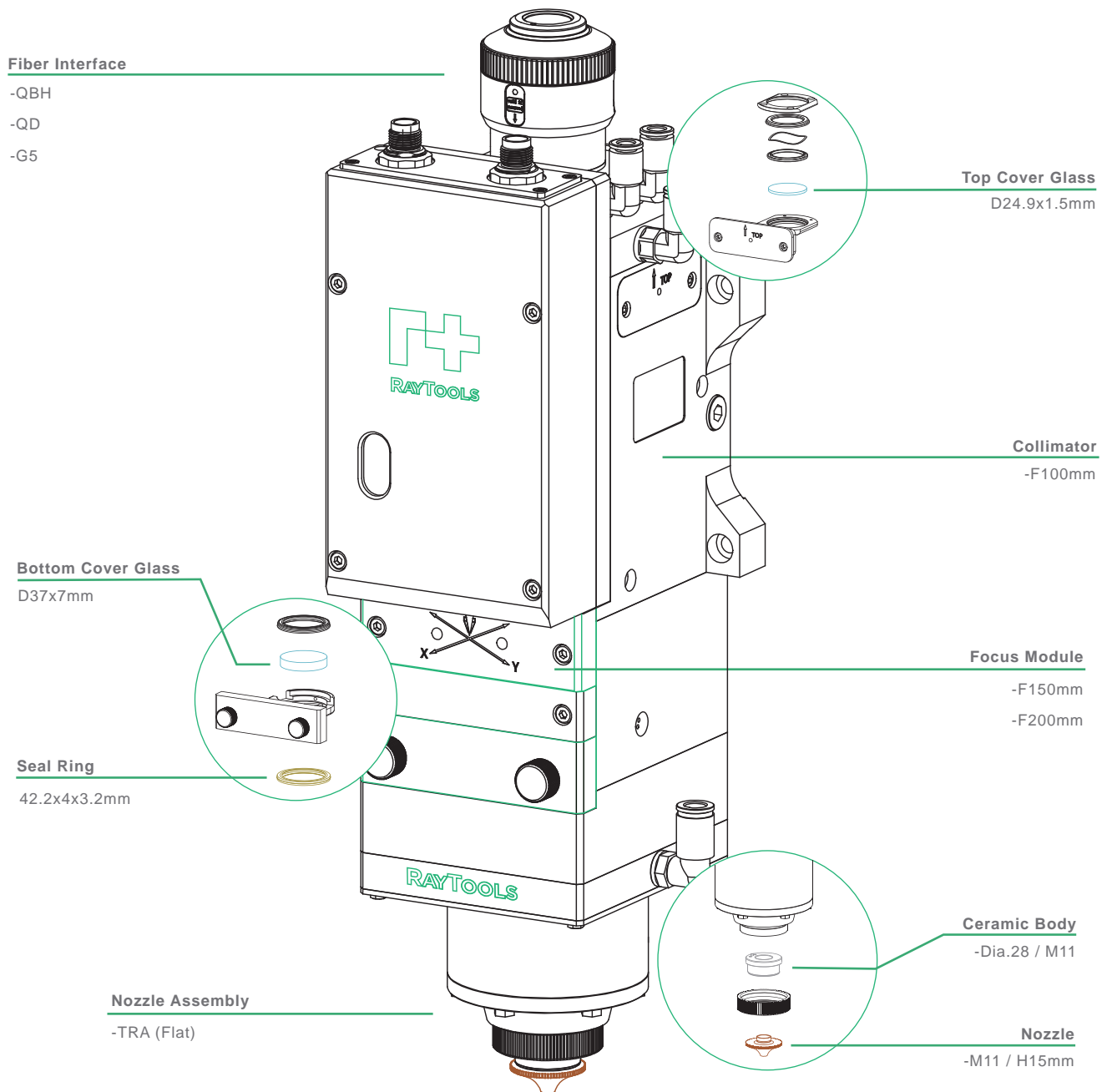



# RAYTOOLS BM111E SERIES



Smart Laser Cutting Head–EtherCAT

Power Rating **3.3KW**

Communication and auto focus control based on EtherCAT.

D30mm combo lens to support laser up to 3.3KW.

4-Color LED lamps to monitor status.

Optimized optical configuration and smooth gas circuit.



Top cover glass is used to further protect collimation lens.

Drawer type cover glass holder to facilitate replacement.

Standard QBH/QD (LLK-D) interfaces to work with different fiber lasers.

## Technical Data

Fiber Interface	QBH, QD
Clear Aperture	28 mm
Auto Focus	
- Range	+10 ~ -14 mm
- Acceleration	≤ 10 m/s <sup>2</sup>
- Velocity	≤ 6 m/min
- Accuracy	≤ 50 μm
Cover Glasses	
- Collimation Side (Top)	Φ24.9 * 1.5 mm
- Focusing Side (Middle/Bottom)	Φ27.9 * 4.1 mm

Collimation Length	75mm, 100mm
Focusing Length	125mm, 150mm, 200mm
Nozzle Styles	Single, Double, Custom
Diameter of Nozzle Tip	0.8mm, 1.0mm, 1.2mm, 1.5mm, 2.0mm, 2.5mm, 3.0mm, 3.5mm, 4.0mm, 4.5mm, 5.0mm
Assist Gas Pressure	≤ 30 bar
Weight	~ 5 kg

Specifications subject to change without notice.

# RAYTOOLS BM114E SERIES



Smart Laser Cutting Head-EtherCAT

Power Rating **6KW**



Communication and auto focus control based on EtherCAT.

4-Color LED lamps to monitor status.

Optimized optical configuration and smooth gas circuit.

Top cover glass is used to further protect collimation lens.

D37mm combo lens to support laser up to 6KW.

Drawer type cover glass holder to facilitate replacement.

Standard QBH/QD (LLK-D) interfaces to work with different fiber lasers.

## Technical Data

Fiber Interface	QBH, QD
Clear Aperture	35 mm
Auto Focus	
- Range	+15 ~ -20 mm
- Acceleration	≤ 10 m/s <sup>2</sup>
- Velocity	≤ 15 m/min
- Accuracy	≤ 50 μm
Cover Glasses	
- Top/Middle	Φ37 * 1.6 mm
- Bottom	Φ37 * 7 mm

Collimation Length	75mm, 100mm
Focusing Length	150mm, 200mm
Nozzle Styles	Single, Double, Custom
Diameter of Nozzle tip	
- Single	1.2-5.0mm
- Double	1.0-1.8mm
- Boost	1.6-7.0mm
Assist gas pressure	≤ 30 bar
Weight	~ 6.2 kg

Specifications subject to change without notice.

RAYTOOLS

# BT240S SERIES

Manual Focus Laser Cutting Head



Power Rating 3.3KW

IP65 dustproof level with fully enclosed beam path to decrease contamination risk.

Zero focus scale recovery function to maintain accurate focus adjustment.



Integrated design and improved QBH fiber interface to prevent from sticking.

Dual-water cooling circuit to collimation lens and focus lens.

## Technical Data

Fiber Interface	QBH, QD
Clear Aperture	28 mm
Collimation Length	100 mm
Focusing Length	125mm, 155mm, 200mm
Cover Glasses	
- Collimation Side(Top)	Φ24.9 * 1.5 mm
- Focusing Side(Bottom)	Φ27.9 * 4.1 mm

Nozzle Styles	Single, Double, Custom
Diameter of Nozzle tip	0.8mm, 1.0mm, 1.2mm, 1.5mm, 2.0mm, 2.5mm, 3.0mm, 3.5mm, 4.0mm, 4.5mm, 5.0mm
Assist gas pressure	≤25 bar
Weight	~ 3.5 kg

Specifications subject to change without notice.

RAYTOOLS

# BT240S SERIES

Manual Focus Laser Cutting Head

Power Rating 3.3KW

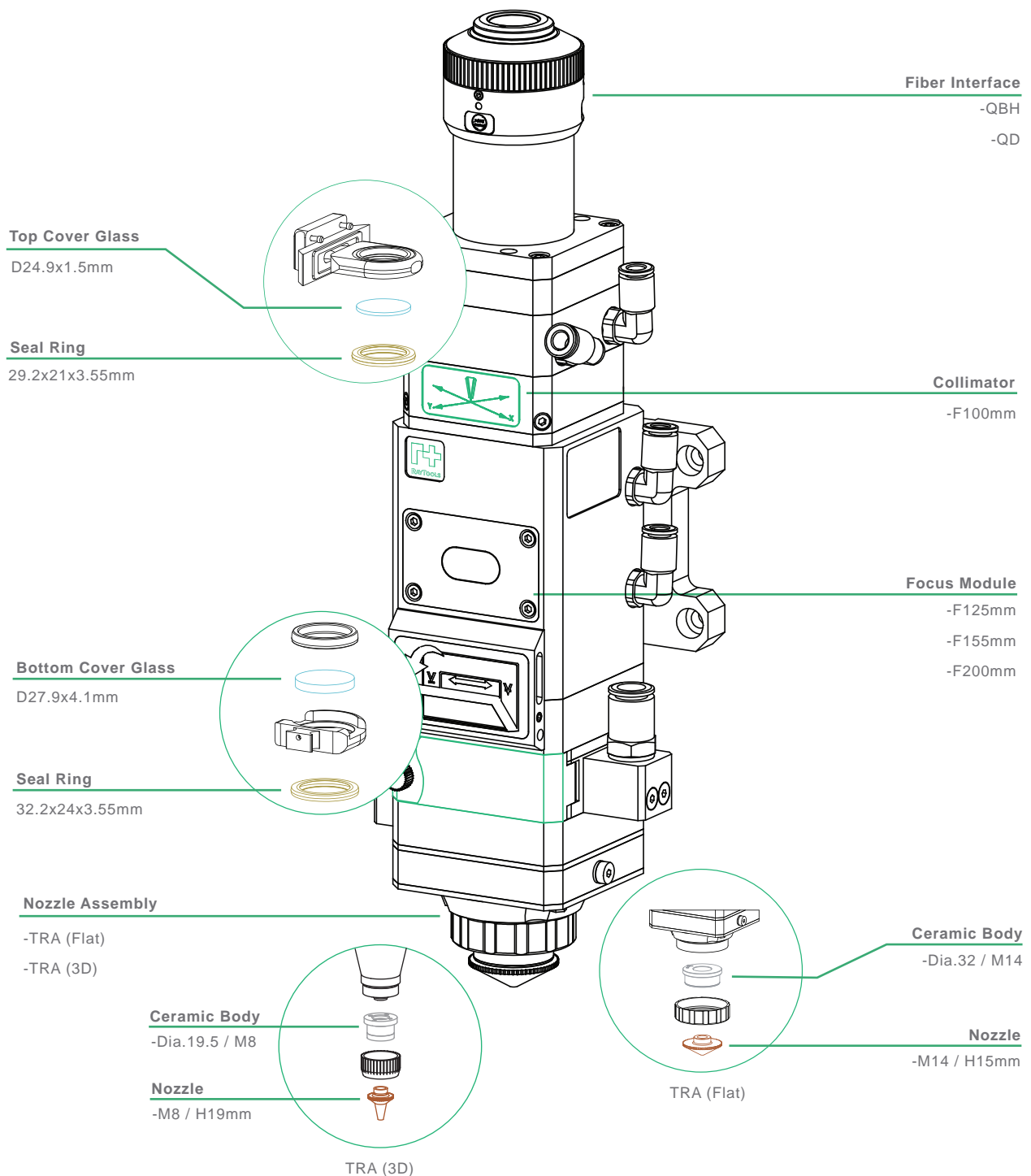

# RAYTOOLS BD04K SERIES



Auto Focus Tube Cutting Head

Power Rating **4KW**

### Excellent Design

Lightweight design with fast acceleration, Optimized optical configuration and efficient air flow design significantly to improve cutting quality and efficiency.

### High Adaptability

With QBH,QD,G5 and other types of optical fiber interfaces, it is applicable to various fiber lasers.



### Sealed Beam Path

Good sealing to keep beam path clean.

### Auto Focus

Automatically change the focus position.

## Technical Data

Item	Specification
Collimation Length	100mm
Focusing Length	200mm
Cover Glasses	
-Top	Φ24.9*1.5mm
-Middle	Φ27.9*4.1mm
-Bottom	Φ27.9*4.1mm
Auto Focus Control	
-Pulse+Direction	
-0~10V Analog	
-EtherCAT	
Beam Alignment	Collimator X/Y
Beam Alignment Range	±1mm

Item	Specification
Focus Adjustment	Focus Lens Moving
Auto Focus Range	-12~+12mm
Fiber Interface	QBH,QD,G5
Weight	~4.8Kg
Nozzle Style	Single/Double
Diameter of Nozzle Tip	1.2mm,1.5mm,2.0mm,2.5mm 3.0mm,3.5mm,4.0mm
Height Follow System	Optional
-Standalone	
-0~10V Analog	
-EtherCAT	

# RAYTOOLS BD04K SERIES



Auto Focus Tube Cutting Head

Power Rating **4KW**

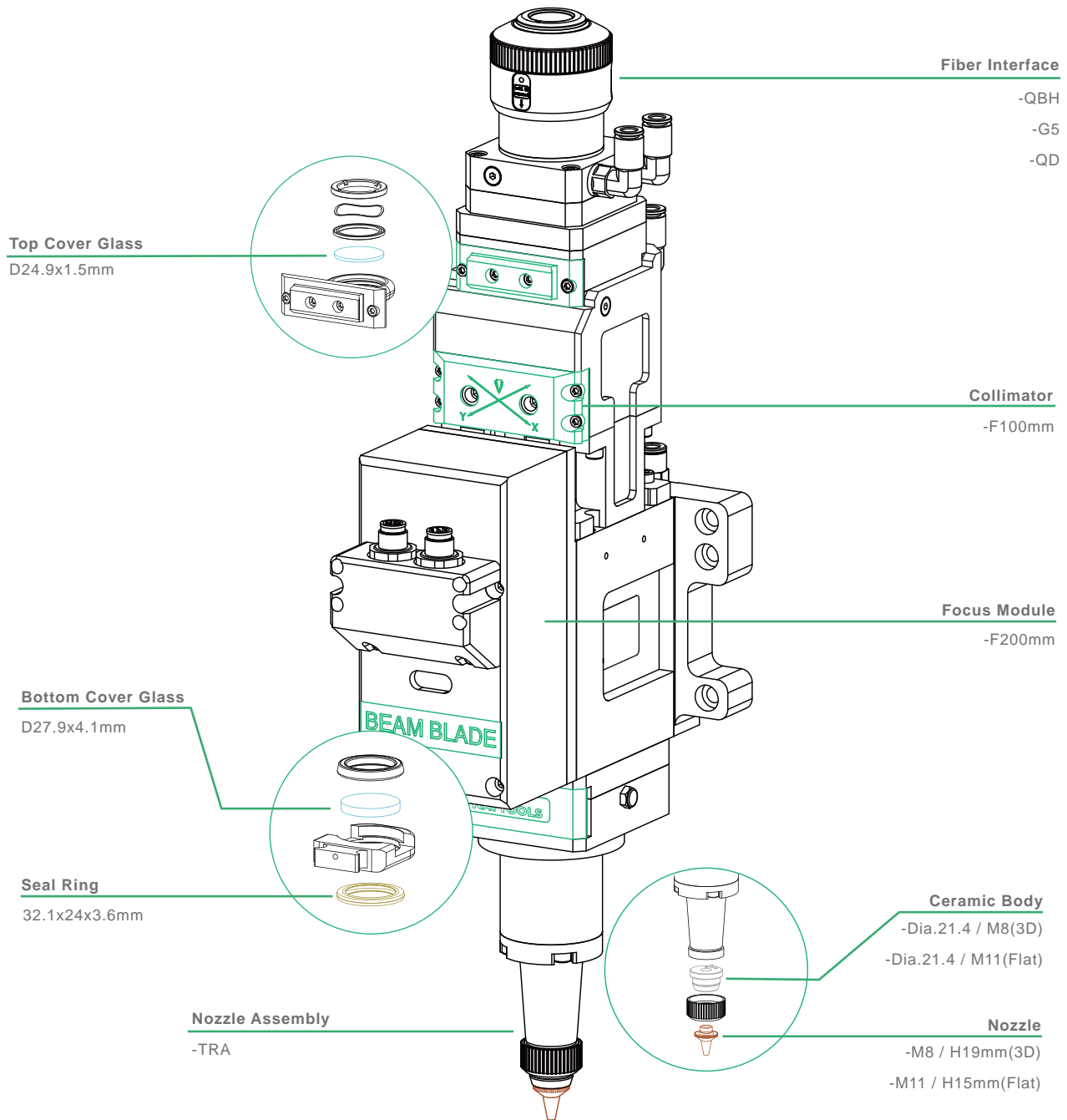

# RAYTOOLS BD08K SERIES



Auto Focus Tube Cutting Head

Power Rating **8KW**

### Excellent Design

Lightweight design with fast acceleration, Optimized optical configuration and efficient air flow design significantly to improve cutting quality and efficiency.

### High Adaptability

With QBH,QD,G5 and other types of optical fiber interfaces, it is applicable to various fiber lasers.

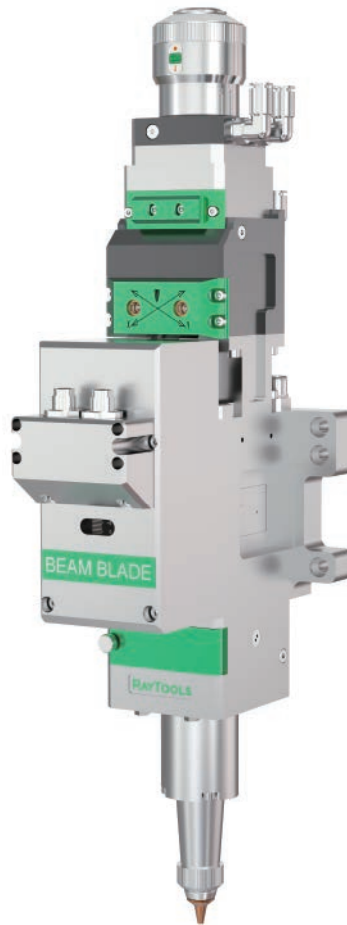

### Sealed Beam Path

Good sealing to keep beam path clean.

### Auto Focus

Automatically change the focus position.

## Technical Data

Item	Specification
Collimation Length	100mm
Focusing Length	200mm
Cover Glasses	
-Top	Φ24.9*1.5mm
-Middle	Φ37*7mm
-Bottom	Φ37*7mm
Auto Focus Control	
-Pulse+Direction	
-0~10V Analog	
-EtherCAT	
Beam Alignment	Collimator X/Y
Beam Alignment Range	±1mm

Item	Specification
Focus Adjustment	Focus Lens Moving
Auto Focus Range	+12~-16mm
Fiber Interface	QBH,QD,G5
Weight	~5Kg
Nozzle Style	Single/Double
Diameter of Nozzle Tip	1.2mm,1.5mm,2.0mm,2.5mm 3.0mm,3.5mm,4.0mm
Height Follow System	Optional
-Standalone	
-0~10V Analog	
-EtherCAT	

# RAYTOOLS BD08K SERIES



Auto Focus Tube Cutting Head

Power Rating **8KW**

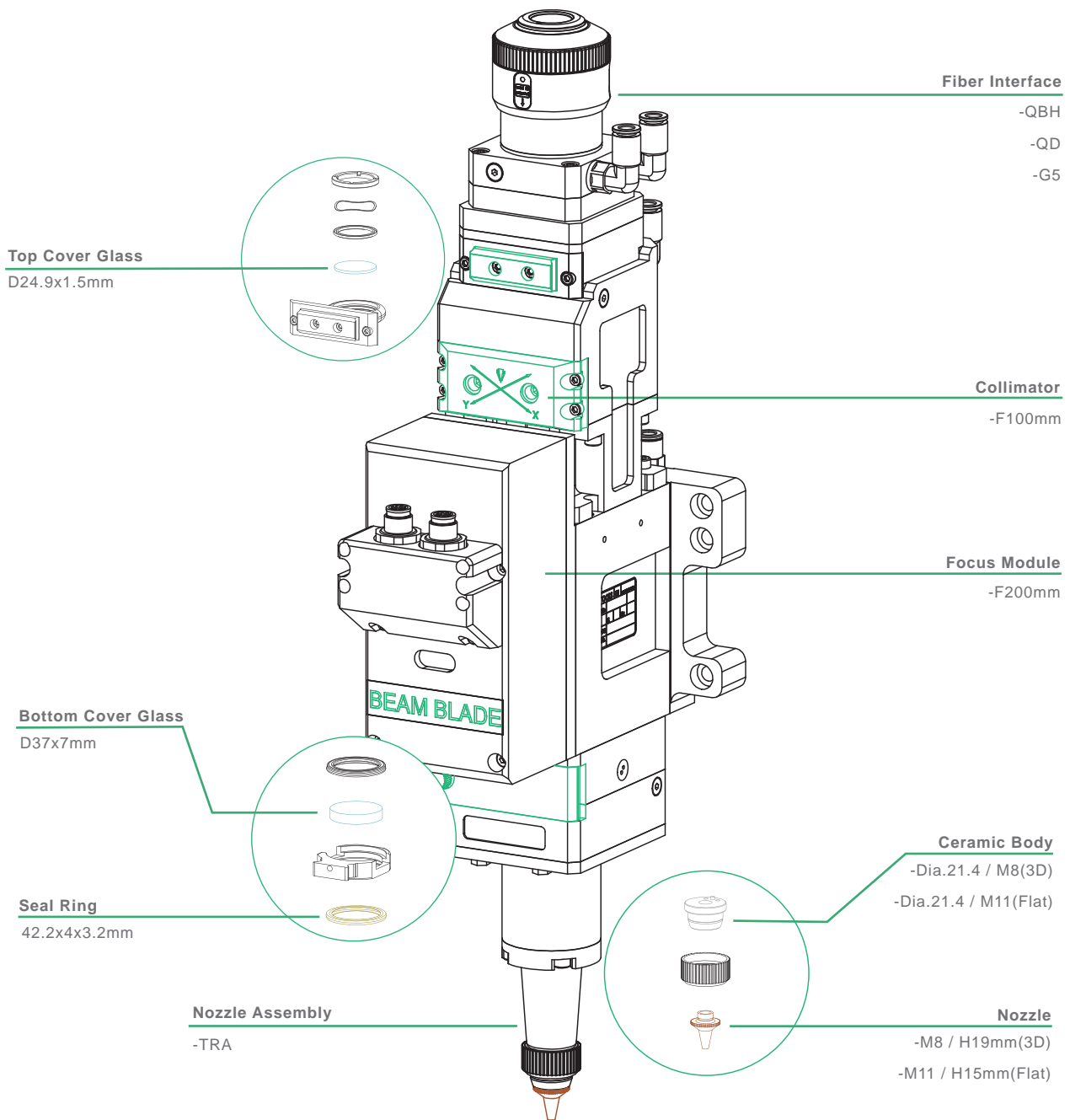



RAYTOOLS

# GF402 SERIES



4-Axis Tube Cutting Head

Power Rating 6KW

## General Feature

- Fully built-in optics system to secure more stable cutting comparing to external optics system.
- Mechanical body machined by aviation aluminium.
- Auto focus by moving of collimation lens to achieve bigger auto focus range with high precision.
- Built-in H (height follow) axis to facilitate side cutting of square tube and H profile.
- Brake function of A (bevel) axis to prevent from crash caused by power failure.
- High rigidity to secure the stability of optics system.

## Horizontal Adjustment

Level adjusting mechanism to adjust mounting angle.



## Control and Drive

Fully close-loop control of A and H axis by using frameless motor and circular grating drive system with compact structure, high precision and outstanding dynamic performance.

## Water and Gas

- Water cooling
- Cutting gas 0-25 bar to be regulated by proportional valve
- Pneumatic brake of A axis by 0-6 bar gas.
- Gas must be oil & water free with 3-stage filtering. (dryer is required)

## Anti-collision

- Anti-collision function to output alarm in case of collision.
- Bevel angle is limited within 6° and trigger inductive safety switch of Z axis when horizontal collision occurs.

## Technical Data

Item	Specification
A axis travel (bevel angle)	±135°
H axis travel (height follow)	±17.5 mm
Auto focus range	±20mm
Fiber interface	QBH/QD/G5
Power rating	6000W
Clear aperture	35mm
Collimation length	100mm

Item	Specifictaion
Focus length	150mm
A axis speed-max	2 rev/s
A axis acceleration-max	125 rad/s <sup>2</sup>
H axis acceleration-max	2g
A axis resolution	0.00006°
A axis positioning accuracy	0.005°
A axis repeated positioning	0.005°
Weight	18kg

Specifications subject to change without notice.

RAYTOOLS

# FM220 SERIES

Micro Laser Cutting Head

Power Rating 2KW



Light-duty and compact design to improve cutting speed and reduce operation space.

Optimized optical configuration and smooth air flow design to improve cutting quality and efficiency.

Fiber interface like QBH or QCS is optional.



Special optical system to eliminate spherical aberration.

Particularly designed micro cutting nozzle to safeguard the performance.

Max shrinkage of beam spot size by 1/2 which is applicable to ultra micro cutting in ceramic, medical and semi-conductor industry, etc.

## Technical Data

Fiber Interface	QBH, QCS
Clear Aperture	25 mm
Follow Distance	20mm
Manual Focus	
- Range	10mm
- Accuracy	≤ 50 μm
Cover Glasses (Bottom)	
- 50/60mm FL	Φ22.4 * 4.1 mm
- 80mm/100mm FL	Φ27.9 * 4.1 mm

Collimation Length	100mm
Focusing Length	50mm, 60mm, 80mm, 100mm
Nozzle Styles	Single
Diameter of Nozzle Tip	0.3mm, 0.5mm, 0.8mm, 1.0mm, 1.5mm, 2.0mm
Assist Gas Pressure	≤ 20 bar
Weight	~ 1.5 kg

Specifications subject to change without notice.

RAYTOOLS

# FM220 SERIES

Micro Laser Cutting Head

Power Rating 2KW



**Fiber Interface**

- QBH
- QCS

**Bottom Cover Glass**

- F80/100mm
- D27.9x4.1mm
- F50/60mm
- D22.4x4.1mm

**Seal Ring**

- F80/100mm:
- 32.2x24x3.55mm
- F50/60mm:
- 26.5x18.5x3.65mm

**Nozzle Assembly**

- TRA (Flat)

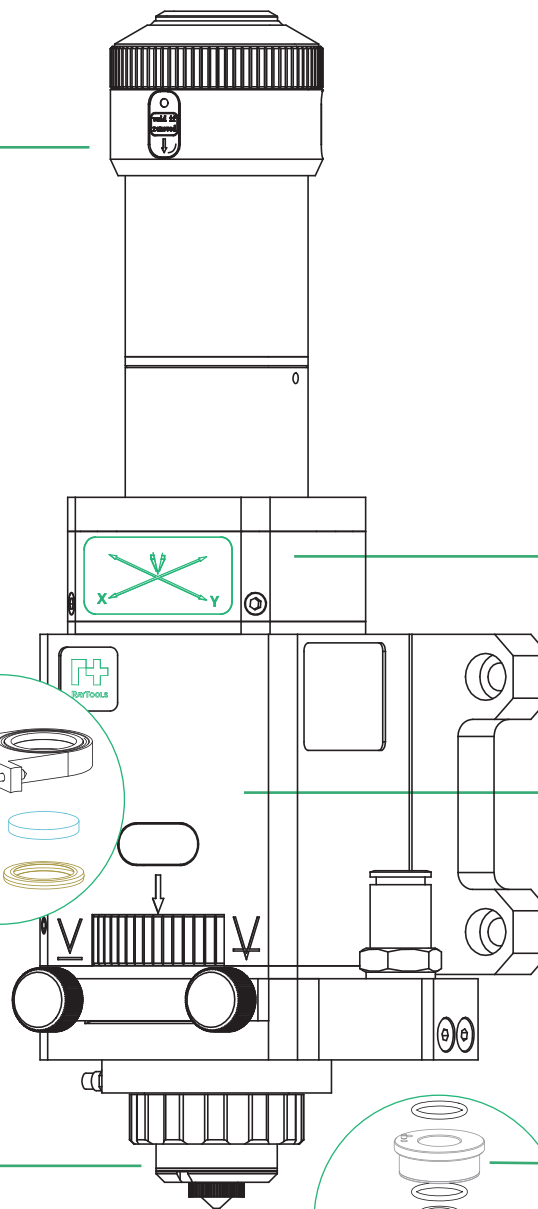

**Collimator**

- F100mm

**Focus Module**

- F50mm
- F60mm
- F80mm
- F100mm

**Ceramic Body**

- Dia.32 / M14

**Nozzle**

- M8 / H10mm

RAYTOOLS

# GF101 SERIES



Robotic Laser Cutting Head with Built-in Z Axis

Power Rating 4KW

Integrated design with built-in Z axis to decrease interference in narrow operation space.

Light-duty and compact design to decrease payload of robot.

Optimized optical configuration and smooth airflow design to meet different applications in thin plate cutting and other customized 3D environment.

Both cover glasses to provide protection to collimation lens and focus lens.



Dual water-cooling circuits to safeguard the continuous operation.

Reliable seal, modular and skinny nozzle structure to reduce interference and prolong lifespan.



BMQ Controller

## Technical Data

Fiber Interface	QBH, QD
Clear Aperture	28 mm
Manual Focus	
- Range	+7 ~ -9 mm
- Accuracy	≤ 50 μm
Cover Glasses	
- Collimation Side (Top)	Φ24.9 * 1.5 mm
- Focusing Side (Bottom)	Φ27.9 * 4.1 mm
Collimation Length	100mm

Focus Length	150mm
Follow Distance	20mm
Nozzle Styles	Single, Double, Custom
Diameter of Nozzle Tip	0.8mm, 1.0mm, 1.2mm, 1.5mm, 2.0mm, 2.5mm, 3.0mm, 3.5mm, 4.0mm
Assist Gas Pressure	≤ 25 bar
Recommended Robot Payload	~20 kg
Weight	~ 3.5 kg

Specifications subject to change without notice.

RAYTOOLS

# GF101+GF102 SERIES



Robotic Laser Cutting Head with Built-in Z Axis and A/B Axis

Power Rating 4KW

Compact design with light-duty to decrease the payload of robot or machine tool.

Excellent dynamic characteristics and high precision.

Programmable A/B axis which is capable of cutting to small contours.

Independent application or along with robot arm.

Standard QBH/QD (LLK-D) interfaces to work with different fiber lasers.



Built-in Z axis design to narrow down operation space and decrease interference.

Drawer type cover glass holder to facilitate replacement.



BMQ Controller

## Technical Data

Fiber Interface	QBH , QD(LLK-D)
Clear Aperture	28 mm
Manual Focus	
- Range	+7 ~ -9 mm
- Accuracy	≤ 50 μm
Cover Glasses	
- Top	Φ24.9 * 1.5 mm
- Bottom	Φ27.9 * 4.1 mm
Collimation Length	100mm

Focus Length	150mm
Min. Cutting Diameter	1mm (accuracy ±0.1mm)
Nozzle Styles	Single, Double, Custom
Diameter of Nozzle Tip	0.8mm, 1.0mm, 1.2mm, 1.5mm, 2.0mm, 2.5mm, 3.0mm, 3.5mm, 4.0mm
Assist Gas Pressure	≤ 25 bar
Weight	~ 11 kg
Recommended Robot Payload	~35-40 kg

Specifications subject to change without notice.

# RAYTOOLS

## BT220RC/BD04K/BD08K +Motorized Slide SERIES



Robotic Laser Cutting Head with External Z Axis

Power Rating 1.5/4/8 KW

### Excellent Design

Lightweight design with fast acceleration. Optimized optical configuration and efficient air flow design to improve cutting quality and efficiency.

### High Adaptability

With QBH, QD, G5 and other types of optical fiber interface, it is applicable to various lasers.

### Sealed Beam Path

Good sealing to keep beam path clean.

### Auto / Manual Focus

Automatic or manual change of focus position.

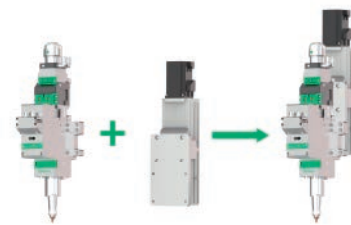

BD08K Slide

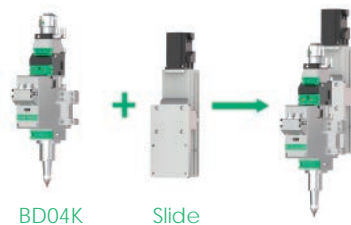

BD04K Slide



BT220RC Slide

### Skinny Nozzle Assembly

Ultra slim nozzle structure to decrease interference for H, L, U profiles cutting as much as possible.

### External Z Axis

External motorized slide to work as Z axis for height follow movement.



BMQ Controller

### Independent Height Follow System

BMQ control cabinet with integrated height follow is used to control external Z axis independently.

## Technical Data

Fiber interface	QBH, QD (LLK-D), G5	- Bottom	Φ27.9 * 4.1mm(BT220RC/BT210SRC/BD04K)
Laser power rating	1.5KW(BT220SRC/BT210SRC)		Φ37mm *7 mm (BD08K)
	4KW (BD04K)	Weight	~ 4kg (BT220RC or BT210SRC with motorized slide)
	8KW (BD08K)		~ 9kg (BD04K with motorized slide)
Collimation length	100mm		~ 9kg (BD08K with motorized slide)
Focusing length	150mm(BT220RC/BT210SRC)	Recommended Robot Payload	~ 20kg (BT220RC or BT210SRC with motorized slide)
	200mm(BD04K/BD08K)		~ 25-30kg (BD04K with motorized slide)
Focus Adjustment	Manual(BT220RC/BT210SRC)		~ 25-30kg (BD08K with motorized slide)
	Auto(BD04K/BD08K)	Operating Temperature	5°C -55°C
Cover glass - Top	Φ24.9 * 1.5 mm	Humidity	30%-95% without condensation
- Middle	Φ27.9 mm * 4.1 mm (BD04K)		
	Φ37mm *7 mm (BD08K)		

Specifications subject to change without notice.

RAYTOOLS

# GF501 SERIES



5-Axis 3D Laser Cutting Head

Power Rating 4KW

### General Feature

- Fully built-in optics system to secure more stable cutting comparing to external optics system. Mechanical body machined by aviation aluminium.
- Auto focus by OA mirror.
- Built-in H (height follow) axis to facilitate side cutting of square tube and H profile.
- Brake function of A (bevel) axis to prevent from crash caused by power failure.
- Internal boosted gas can be used to prevent from optics contamination.
- High rigidity to secure the stability of optics system.

### Horizontal Adjustment

Level adjusting mechanism to adjust mounting angle.

### Height Follow

Originally Europe made height controller to secure stable 5 axis cutting.



### Control and Drive

Fully close-loop control of A and H axis by using frameless motor and circular grating drive system with compact structure, high precision and outstanding dynamic performance.

### Water and Gas

- Water cooling
- Cutting gas 0-15 bar to be regulated by proportional valve
- Auto focus by 0-6 bar gas to be regulated by proportional valve.
- Internal boosted gas 0-2 bar. Maintain positive pressure inside.
- Gas must be oil & water free with 3-stage filtering. (dryer is required)

### Anti-collision

- Anti-collision function to output alarm in case of collision.
- Bevel angle is limited within 6° and trigger inductive safety switch of Z axis when horizontal collision occurs.

## Technical Data

Item	Specification
A axis travel (bevel angle)	±135°
C axis travel (rotation angle)	±540°
H axis travel (height follow)	±17.5mm
Auto focus range (OA mirror)	±9mm
Fiber interface	QBH
Power rating	4000W
Clear aperture	35mm
Collimation length	100mm

Item	Specification
Focus length	150mm
A, C axis speed-max	2 rev/s
A, C axis acceleration-max	125 rad/s <sup>2</sup>
H axis acceleration-max	2g
A, C axis resolution	0.00006°
A, C axis positioning accuracy	0.005°
A, C axis repeated positioning accuracy	0.005°
Weight	35kg

Specifications subject to change without notice.



## Europe

### RayTools AG.

📍 Friedeggstrasse 13, Postfach, 3400 Burgdorf, Switzerland

✉ [sales@raytools.com](mailto:sales@raytools.com)

🌐 [www.raytools.ch](http://www.raytools.ch)

## North/South America

### RayTools Inc.

📍 10 Wedge Pond Road, Winchester MA 01890, United States

✉ [sales@raytools.com](mailto:sales@raytools.com)

🌐 [www.raytools.ch](http://www.raytools.ch)

## Asia Pacific/South & Middle Asia/Middle East/Africa

### Raytools Automation (Shanghai) Co., Ltd

📍 8 Dongbao Road, Shanghai 201613, China

✉ [sales@raytools.com](mailto:sales@raytools.com)

🌐 [www.raytools.ch](http://www.raytools.ch)

## China

### Shanghai Empower Technologies Co., Ltd

📍 8 Dongbao Road, Shanghai 201613, China

✉ [sales@empower.cn](mailto:sales@empower.cn)

🌐 [www.empower.cn](http://www.empower.cn)